

INSTALLATION MANUAL

COLOR GPS/PLOTTER/SOUNDER

GP-1650F/1650DF

System Configuration	i
Equipment Lists	ii
1. Installation of Standard Equipment	1-1
1.1 Installation of Display Unit	1-1
1.2 Installation of Antenna Unit (GP-1650DF only)	1-3
1.3 Installation of Transducers	1-4
1.4 Installation of Sensors	1-14
2. Wiring	2-1
3. Initial Settings	3-1
3.1 NMEA Setting	3-1
3.2 Output Data Sentences	3-3
3.3 Antenna Height	3-4
3.4 Baud Rate Setting (GP-1650DF only)	3-5
3.5 Beacon frequency Setting (GP-1650DF only)	3-6
3.6 Depth Adjustment	3-7
3.7 External Equipment Setup (Option)	3-8
4. Installation of DGPS Beacon Receiver (for GP-1650F)	4-1
APPENDIX TRIDUCER 525ST-PWC/PWD	AP-1
PACKING LIST	A-1
OUTLINE DRAWINGS	D-1
INTERCONNECTION DIAGRAM	S-1
SCHEMATIC DIAGRAM	S-2



© **FURUNO ELECTRIC CO., LTD.**

9-52 Ashihara-cho,
Nishinomiya, Japan

Telephone : 0798-65-2111

Telefax : 0798-65-4200

Your Local Agent/Dealer

All rights reserved.

Printed in Japan

FIRST EDITION : NOV. 1998

N : FEB. 06,2002

PUB.No. IME-43942-N

(TATA) GP-1650F/1650DF



* 0 0 0 8 0 8 5 6 8 0 1 *



* I M E 4 3 9 4 2 N 0 0 *



SAFETY INSTRUCTIONS

Safety Instructions for the Installer



WARNING



Do not work inside the equipment unless totally familiar with electrical circuits.

Hazardous voltage which can shock, burn or cause serious injury exists inside the equipment.



Turn off the power at the mains switchboard before beginning the installation. Post a sign near the switch to indicate it should not be turned on while the equipment is being installed.

Fire, electrical shock or serious injury can result if the power is left on or is applied while the equipment is being installed.



CAUTION

When handling the transducer cable, keep in mind the following points.

- Keep the cable away from oil and fuel.
- Keep the cable away from the place where it may be damaged during the installation.
- Do not paint the cable.

The sheath of the transducer cable is made of chlorophrene rubber (or vinyl chloride). Therefore, do not paint the sheath with organic liquid (such as toluene) since it may harm the sheath.



CAUTION



Ground the equipment to prevent electrical shock and mutual interference.

Confirm that the power supply voltage is compatible with the voltage rating of the equipment.

Connection to the wrong power supply can cause fire or equipment damage. The voltage rating appears on the label at the rear of the display unit.

Use the correct fuse.

Use of a wrong fuse can cause fire or equipment damage.

Keep the following compass safe distance.

	Standard	Steering
Display Unit	0.82 m	0.62 m

A warning label is attached to the equipment. Do not remove the label. If the label is missing or illegible, contact a FURUNO agent or dealer.



Name: Warning Label (1)
Type: 86-003-1011-0
Code No.: 100-236-230

System Configuration

The GP-1650F/1650DF mainly consists of a display unit, a GPS antenna and a dual frequency transducer. A DGPS beacon receiver is provided inside the display unit for GP-1650DF type. The chart card drive in the display unit loads electronic charts. External equipment which can be connected include water temperature and speed sensors, autopilot, and DGPS beacon receiver.

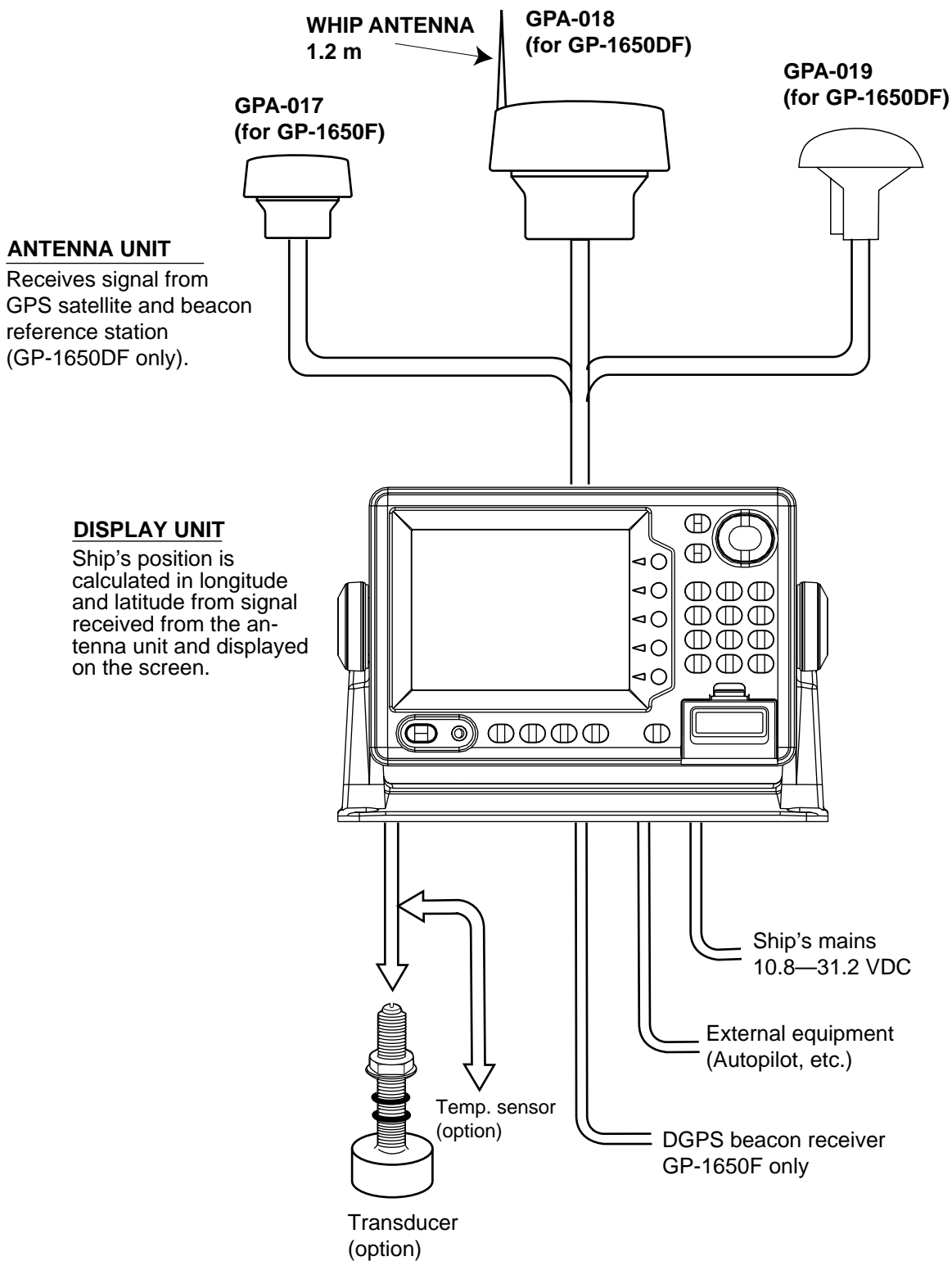

Equipment Lists

Standard supply

No.	Name	Type	Code No.	Qty	Remarks
1	Display Unit	GP-1650F-E	—	1	for GP-1650F
		GP-1650DF-E	—		for GP-1650DF
2	Antenna Unit	GPA-017	000-041-403	1	for GP-1650F
		GPA-018	000-041-407		for GP-1650DF
		GPA-019	000-041-551		for GP-1650DF
3	Spare Parts	SP14-02401	004-374-630	1	
4	Installation Materials	CP14-05100	000-041-480	1	
5	Accessories	FP14-02301	004-375-830	1	Hard cover
		FP14-02302	004-375-850	1	screws for hanger, screws for flush mount.

Optional equipment

No.	Name	Type	Code No.	Remarks
1	Beacon Receiver Kit	GR-802-1650-10A-018	000-041-651	GPA-018, GR-7000A, Whip ant.
		GR-802-1650-10N-018	000-041-482	GPA-018, GR-7000A
		GR-802-1650-15A-018S	000-041-652	GPA-018S, GR-7000A TBC-PS-3D-15, Whip ant.
		GR-802-1650-15N-018S	000-041-483	GPA-018S, GR-7000A TBC-PS-3D-15
		GR-802-1650-10N-019	000-041-650	GPA-019, GR-7000A
		GR-802-1650-15N-019S	000-041-653	GPA-019S, GR-7000A TBC-PS-3D-15
2	Antenna cable Set	CP20-01700	004-372-110	30 m, for antenna cable extension
		CP20-01710	004-372-120	50 m, for antenna cable extension
3	Antenna cable assy.	TNC-PS-3D-15	000-133-670	15m, for antenna cable extension
4	Cable Assy.	MJ-A7SPF0003-050	000-136-730-01	
5	Mast mount fixture	CP20-0111	004-365-780	
6	Right-angle antenna base	No.13-QA330	000-803-239	for mounting antenna unit
7	L-angle antenna base	No.13-QA310	000-803-240	
8	Antenna base for rail mounting	No.13-RC5160	000-806-114	

Optional equipment (con't)

No.	Name	Type	Code No.	Remarks
9	Antenna Unit	GP-018S	000-041-462	for GP-1650DF
		GP-016	000-040-536	for GP-1650F
		GPA-019S	000-041-554	for GP-1650DF
10	Transducer	520-5PSD	000-015-125	
		520-5PWD	000-015-126	With 8 m cable transom mount
		520-5MSD	000-015-127	With 8 m cable and water proof connector
11	ST sensor	ST-02MSB	000-137-986	Thru-hull type
		ST-02PSB	000-137-987	With 8m cable, thru-hull type
12	Inner hull Kit S	22S0191	000-802-598	
13	Temperature sensor	T-02MTB	000-040-026	
		T-02MSB	000-040-040	
		T-03MSB	000-040-027	
14	Dual frequency Transducer	524ST-MSD	000-015-224	
		525ST-MSD	000-015-263	
		520ST-PWD	000-015-128	
		525ST-PWD	000-015-261	
15	Converter Connector	02S4147	000-141-082	
16	Rectifier	PR-62	000-013-484	for 100VAC
			000-013-485	for 110VAC
			000-013-486	for 220VAC
			000-013-487	for 230VAC
17	Whip antenna	FAW-1.2	000-130-046	for GPA-018/018S
18	Cable Assy.	MJ-A6SPF0012-100	000-133-817	6P-6P, 10m
		MJ-A6SPF0007-100	000-125-237	6P-6P, 10m, for autopilot
		MJ-A6SPF0012-050	000-134-424	6P-6P, 5m
		MJ-A6SPF0011-050	000-132-244	6P-4P, 5m
		MJ-A6SPF0011-100	000-132-336	6P-4P, 10m
19	RAM Card	00RAM02MC-004	004-371-790	2MB
20	DGPS Beacon Receiver	GR-80	-	for GP-1650F

1. Installation of Standard Equipment

1.1 Installation of Display Unit

Mounting considerations

The display unit can be installed on a tabletop, on the overhead or flush mounted in a console or panel.

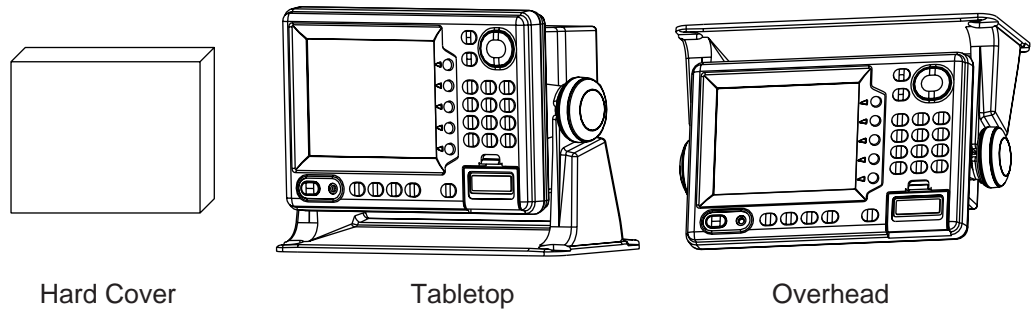

Figure 1-1 Tabletop, overhead mounting methods

When selecting a mounting location for the display unit keep the following in mind:

- Keep the display unit out of direct sunlight.
- The temperature and humidity should be moderate and stable.
- Locate the unit away from exhaust pipes and vents.
- The mounting location should be well ventilated.
- Mount the unit where shock and vibration are minimal.
- Keep the unit away electromagnetic field generating equipment such as motor, generator.
- For maintenance and checking purposes, leave sufficient space at the sides and rear of the unit and leave slack in cables.
- A magnetic compass will be affected if placed too close to the display unit. Observe the following compass safe distances to prevent disturbance to the magnetic compass:

Standard compass: 0.82 meters

Steering compass: 0.62 meters

Mounting procedure

Follow the procedure below to mount the display unit on a tabletop or the overhead.

Tabletop, overhead mounting

1. Fix the hanger by four pan head screws M5 X 16.
2. Screw knob bolts in display unit, set it to hanger, and tighten knob bolts.
3. Attach hard cover to protect LCD.

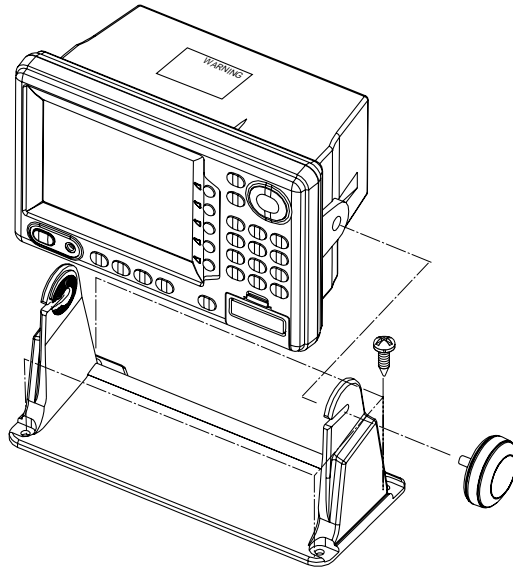
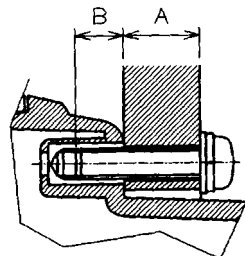

Figure 1-2 Tabletop, overhead mounting of display unit

Flush mounting

Note: Use supplied pan head screws when the thickness of the bulkhead is from 11 to 14 mm. For bulkhead which exceeds 14 mm in thickness the length of the pan head screws should be bulkhead thickness+7.8±1.5 mm. Also the length of B should max. 8mm.



1. Prepare a cutout in the mounting location whose dimensions are as shown in Figure 1-3.
2. Fix the display unit by six pan head screws M4 X 20. Refer to the outline drawing on page D-2.

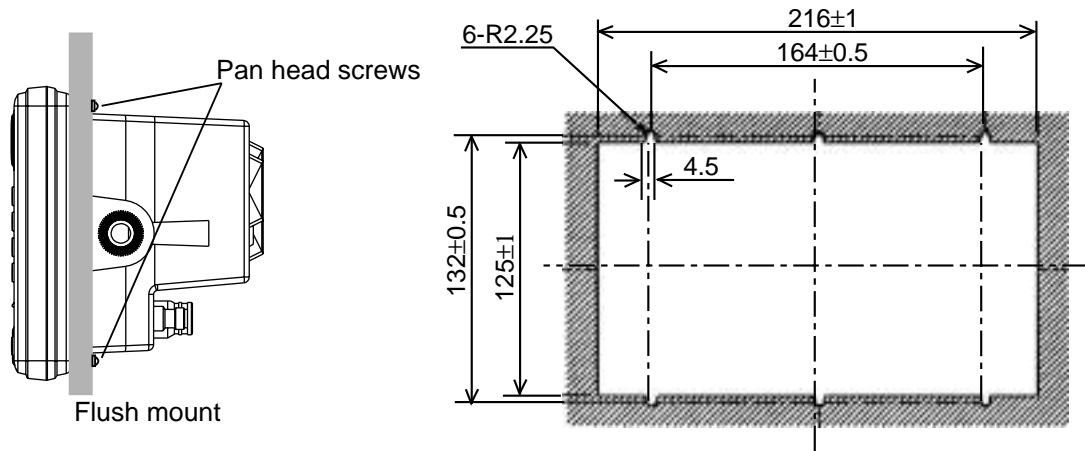

Figure 1-3 Flush mounting of display unit

1.2 Installation of Antenna Unit (GP-1650DF only)

Mounting considerations

Install the antenna unit referring to the installation diagram on page D-3 or D-4. When selecting a mounting location for the antenna unit, keep in mind the following points:

- Select a location out of the radar beam. The radar beam will obstruct or prevent reception of the GPS satellite signal.
- The location should be well away from a VHF antenna. A GPS receiver is interfered by a harmonic wave of a VHF antenna.
- There should be no interfering object within the line-of-sight to the satellites. Objects within line-of-sight to a satellite, for example, a mast, may block reception or prolong acquisition time.
- Mount the antenna unit as high as possible. Mounting the antenna unit as high as possible keeps it free of interfering objects and water spray, which can interrupt reception of GPS satellite signal if the water freezes.
- The length of the whip antenna for the GP-1650DF should be no longer than 1.2 meter to prevent antenna damage. **Do not use a 2.5 meter whip antenna.**
- Do not shorten the antenna cable.
- If the antenna cable is to be passed through a hole which is not large enough to pass the connector, you may unfasten the connector with a needle nose pliers and 3/8-inch open-end wrench. Re-fasten it as shown in Figure 1-4 after running the cable through the hole.

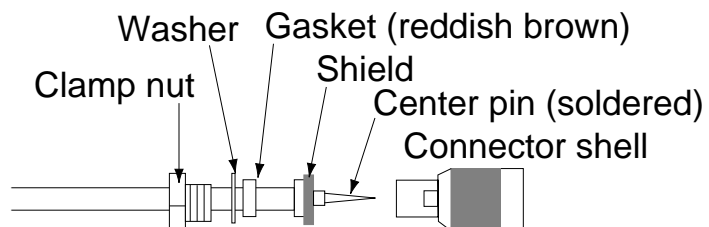

Figure 1-4 How to assemble the connector

1.3 Installation of Transducers

Installing the inside-hull mount transducer

Necessary tools

You will need the following tools:

- Sandpaper (#100)
- Silicone sealant
- Silicone grease

Remarks on installation

- Do the installation with the boat hauled out of the water.
- Turn off the engine while installing the equipment.
- Install the transducer in the engine room.

Selecting the mounting location

Keep the following points in mind when selecting a mounting location:

- The mounting location should be where the hull is of single-hull thickness and is void of air or flotation materials other than solid fiberglass between the transducer face and the water.
- Do not place the transducer over hull struts or ribs which run under the hull.
- Avoid a location where the rising angle of the hull exceeds 15° , to minimize the effect of the boat's rolling.
- You will finalize the mounting location through some trial and error. The procedure for this is shown later.

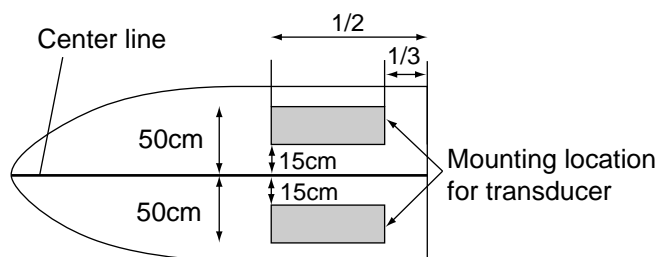

Figure 1-5 Inside-hull transducer mounting location

Attaching the transducer

1. Clean the transducer face to remove any foreign material. Lightly roughen the transducer face with #100 sandpaper. Also, roughen the inside of the hull where the transducer is to be mounted.
2. Warm the silicone sealant to 40°C before usage to soften it. Coat the transducer face and mounting location with silicone sealant.

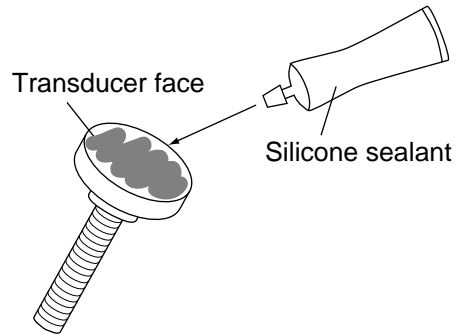

Figure 1-6 Coating the transducer face with silicone sealant

3. Press the transducer firmly down on the hull and gently twist it back and forth to remove any air which may be trapped in the silicone sealant.

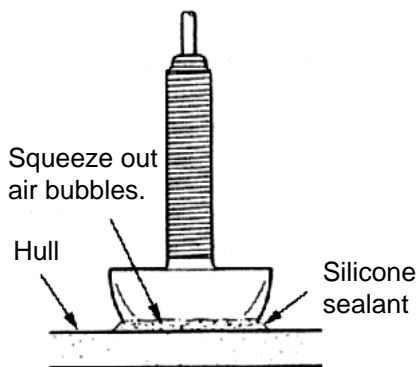

Figure 1-7 Attaching transducer to hull with silicone sealant

Observing the picture

1. Press the [POWER] key to turn on the display unit.
2. Press the [SNDR] key to select the sounder display.
3. Press the soft key labeled "MODE/FREQ" to display the following message.

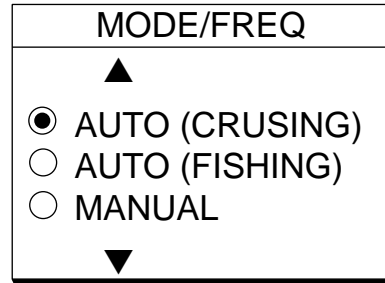

Figure 1-8 MODE FREQ selection screen

4. Select "MANUAL" by the arrow key.
5. Press the soft key labeled "RETURN".
6. Press the soft key labeled "GAIN" to display the following message.

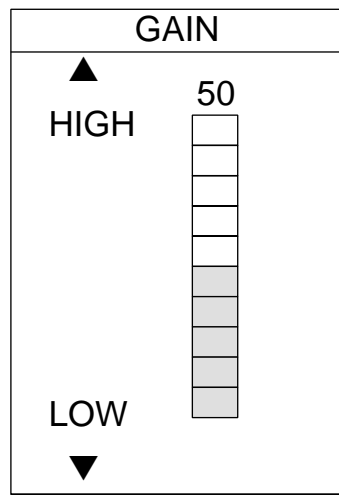

Figure 1-9 GAIN adjustment screen

7. Confirm that Gain is set at 50 (midpoint).
8. Press the soft key labeled "RETURN".
9. Press the soft key labeled "RANGE".
10. Select "15ft" by the [▲] key.
11. Note the depth to the seabed.

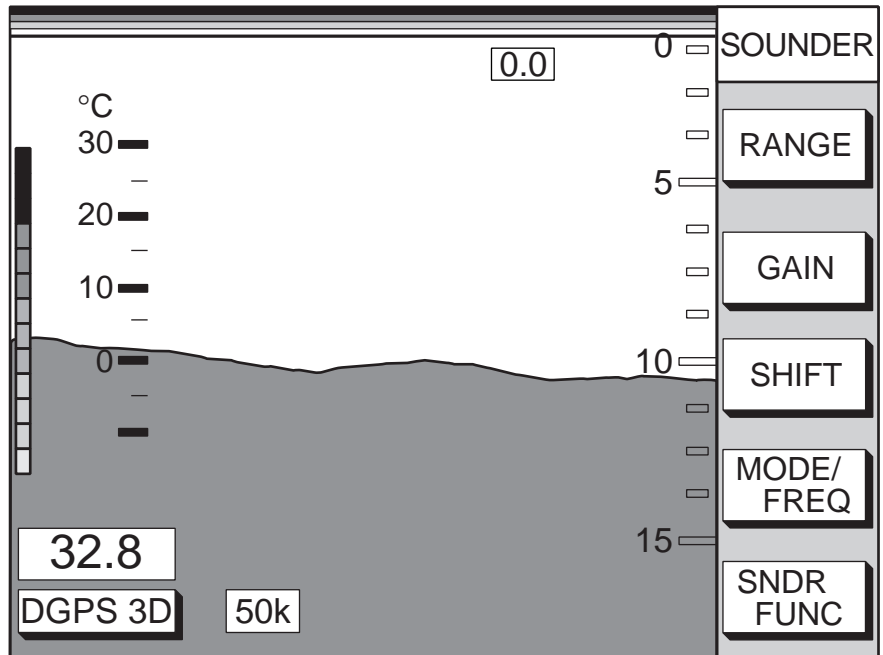

Figure 1-10 Video sounder picture

If the bottom is displayed in red and the light-blue color appears the mounting location is suitable. You can leave the transducer in position.

If the bottom is not displayed in reddish brown, the mounting location is unsuitable. Relocate the transducer and do the following.

1. Press the [POWER] key to turn off the power.
2. Gently dismount the transducer with piece of wood.
3. Do steps 1 through 5 in the previous procedure. Repeat until a suitable location is found.

Final preparation

Support the transducer with a piece of wood to keep it in place while it is drying. Let the transducer dry 24–72 hours.

Installing the thru-hull mount transducer

Transducer mounting location

This type of mounting provides the best performance of all, since the transducer protrudes from the hull and the effect of air bubbles and turbulence near the hull skin is reduced. When the boat has a keel, the transducer should be at least 30 cm away from it. Typical through hull mountings are shown in the figure on the next page.

The performance of the video sounder is directly related to the mounting location of the transducer, especially for high-speed cruising. The installation should be planned in advance, keeping the standard cable length (8 m) and the following factors in mind:

- Air bubbles and turbulence caused by movement of the boat seriously degrade the sounding capability of the transducer. The transducer should, therefore, be located in a position where water flow is the smoothest. Noise from the propellers also adversely affects performance and the transducer should not be mounted nearby. The lifting strakes are notorious for creating acoustic noise, and these must be avoided by keeping the transducer inboard of them.
- The transducer must always remain submerged, even when the boat is rolling, pitching or up on a plane at high speed.
- A practical choice would be somewhere between 1/3 and 1/2 of the boat's length from the stern. For planing hulls, a practical location is generally rather far astern, so that the transducer is always in water regardless of the planing attitude.

Transducer outline drawings

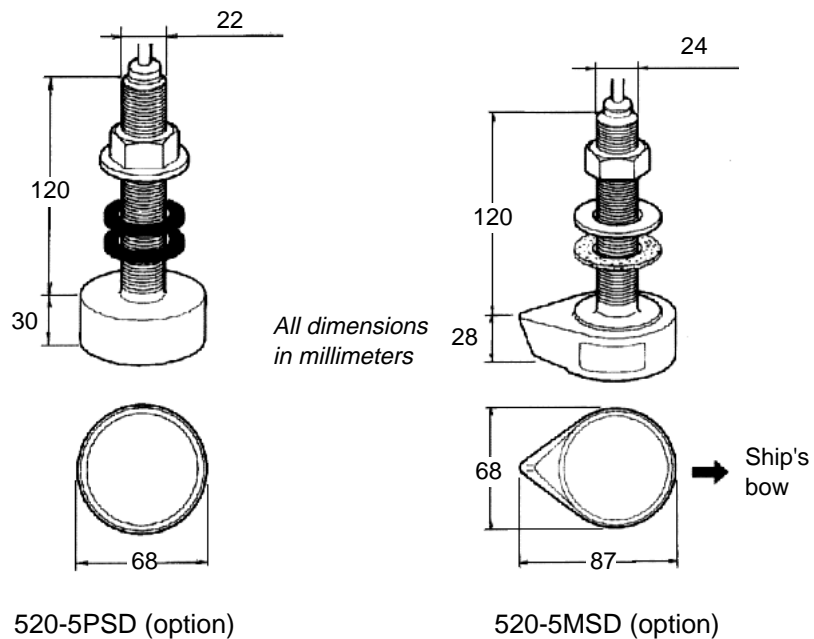
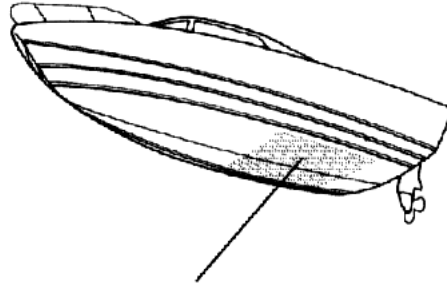

Figure 1-11 Transducer outline drawings

Acceptable transducer mounting locations

Deep-V hull



- Position 1/2 to 1/3 length of the hull from stern
- 15 to 30 cm off center line (inside first lifting strakes).

Figure 1-12 Transducer mounting location on deep-V hull

High speed V-planing hull

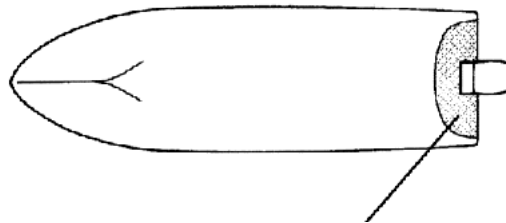
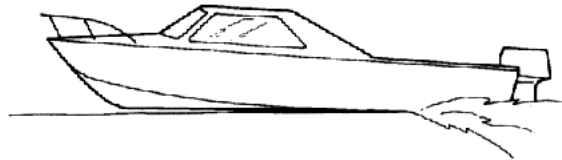

- Within the wetted bottom area
- Deadrise angle within 15°

Figure 1-13 Transducer mounting location on high speed V-planing hull

Typical through-hull mount transducer installations

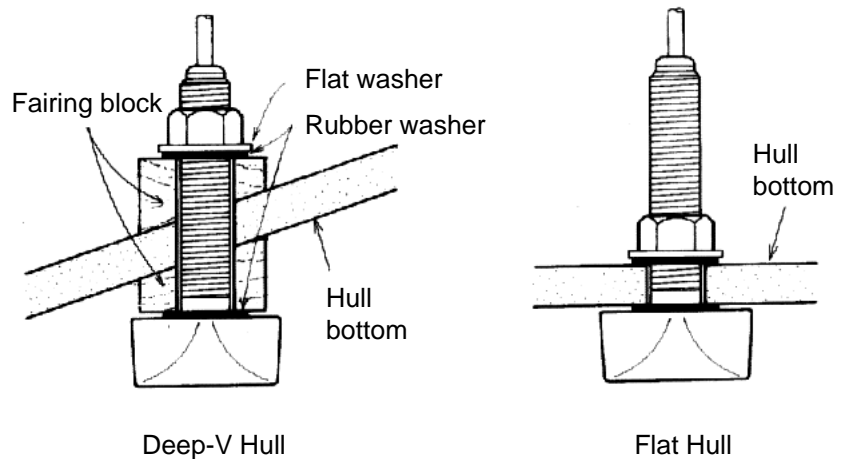

Figure 1-14 Typical through-hull mount transducer installations

Procedure for installing the thru-hull mount transducer

1. With the boat hauled out of the water, mark the location selected for mounting the transducer on the bottom of the hull.
2. If the hull is not level within 15° in any direction, fairing blocks made out of teak should be used between the transducer and hull, both inside and outside, to keep the transducer face parallel with the water line. Fabricate the fairing block as shown below and make the entire surface as smooth as possible to provide an undisturbed flow of water around the transducer. The fairing block should be smaller than the transducer itself to provide a channel to divert turbulent water around the sides of the transducer rather than over its face.

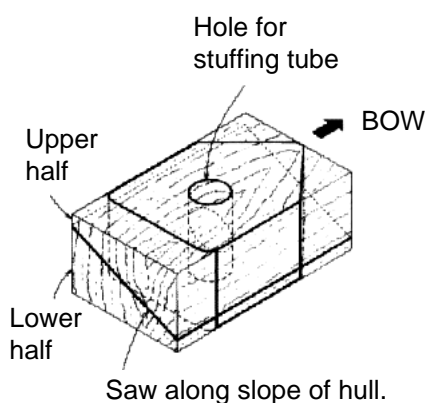

Figure 1-15 Construction of fairing block

3. Drill a hole just large enough to pass the threaded stuffing tube of the transducer through the hull, making sure it is drilled vertically.
4. Apply a sufficient amount of high quality caulking compound to the top surface of the transducer, around the threads of the stuffing tube and inside the mounting hole (and fairing blocks if used) to ensure watertight mounting.
5. Mount the transducer and fairing blocks and tighten the locking nuts. Be sure that the transducer is properly oriented and its working face is parallel to the waterline.

Note: *Do not over-stress the stuffing tube and locking nuts through excessive tightening, since the wood block will swell when the boat is placed in the water. It is suggested that the nut be tightened lightly at installation and retightened several days after the boat has been launched.*

Installing the transom mount transducer

This type of mounting is very commonly employed, usually on relatively small I/O or outboard boats. Do not use this method on an inboard motor boat because turbulence is created by the propeller ahead of the transducer.

There are two methods of installation: flush with hull (for flat hulls) and projecting from hull (for deep V-hulls).

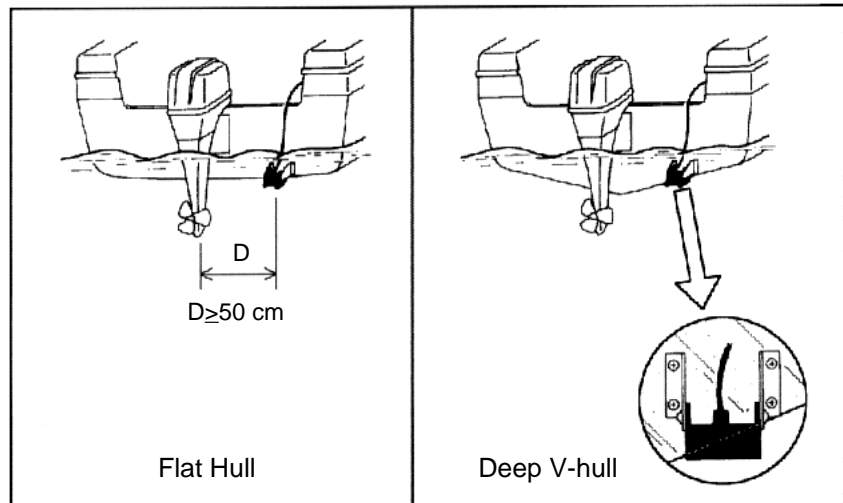

Figure 1-16 Transom mount transducer mounting locations

Installing the transom mount transducer flush with hull (for flat hulls)

A suitable mounting location is at least 50 cm away from the engine and where the water flow is smooth.

1. Drill four pilot holes in the mounting location.
2. Attach the transducer to the bracket with tapping screws (supplied).
3. Adjust the transducer position so the transducer faces right to the seabed.

Note: *If necessary, to improve water flow and minimize air bubbles staying on the transducer face, incline the transducer about 5° at the rear. This may require a certain amount of experimentation for fine tuning at high cruising speeds.*

4. Fill the gap between the wedge front of the transducer and transom with epoxy material to eliminate any air spaces.

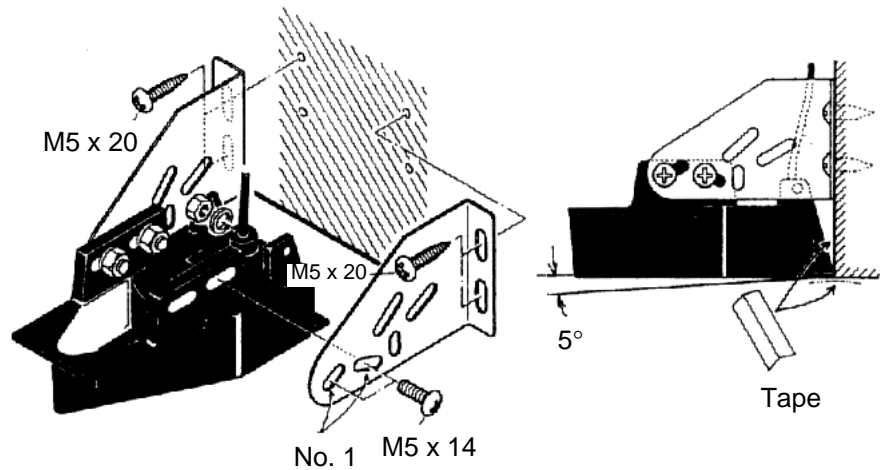

Figure 1-17 Transom mount transducer, mounting flush with hull

Installing the transom mount transducer projecting from hull (for deep-V hulls)

This method is employed on deep-V hulls and provides good performance because the effects of air bubbles are minimal. Install the transducer parallel with water surface; not flush with hull. If the boat is placed on a trailer care must be taken not to damage the transducer when the boat is hauled out of the water and put on the trailer.

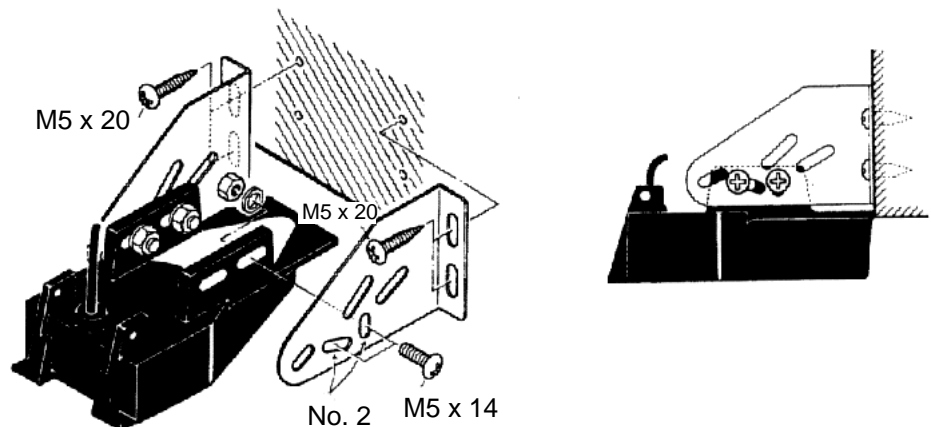

Figure 1-18 Transom mount transducer, projecting from hull

Transducer preparation

Before putting the boat in water, wipe the face of the transducer thoroughly with a detergent liquid soap. This will lessen the time necessary for the transducer to have good contact with the water. Otherwise the time required for complete "saturation" will be lengthened and performance will be reduced.

Do not paint the transducer. Performance will be affected.

Triducer 524ST-MSD, 525ST-MSD

The triducer is designed for thru-hull mounting.

Mounting considerations

When selecting a mounting location keep the following points in mind:

- Air bubbles and turbulence caused by movement of the boat seriously degrade the sounding capability of the transducer. The transducer should, therefore, be located in a position where water flow is the smoothest. Noise from the propellers also adversely affects performance and the transducer should not be mounted nearby. The lifting strakes are notorious for creating acoustic noise, and these must be avoided by keeping the transducer inboard of them.
- The transducer must always remain submerged, even when the boat is rolling, pitching or up on a plane at high speed.
- A practical choice would be somewhere between 1/3 and 1/2 of the boat's length from the stern. For planing hulls, a practical location is generally rather far astern, so that the transducer is always in water regardless of the planing attitude.

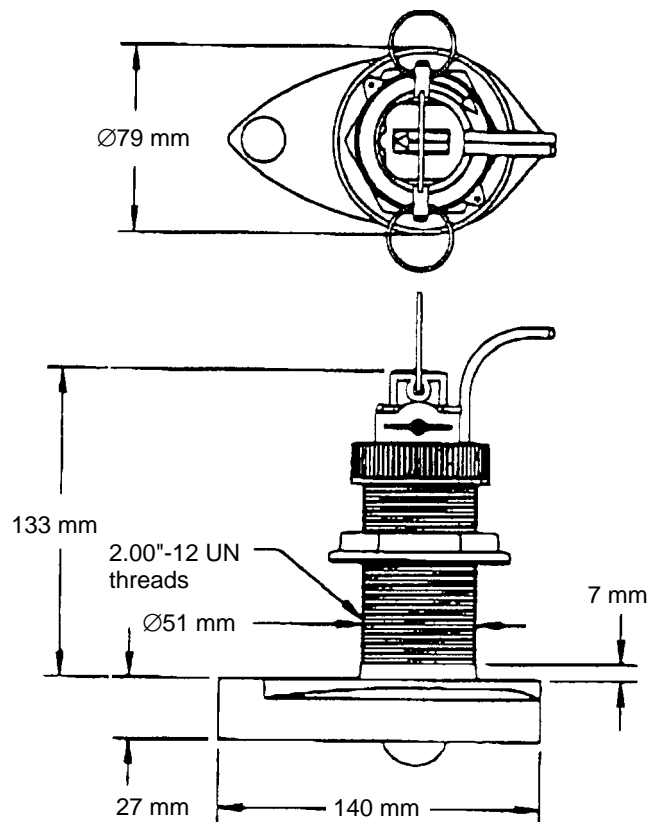

Figure 1-19 Dimensions of triducer 524ST-MSD/525ST-MSD

1.4 Installation of Sensors

Transom mount water temperature sensor T-02MTB

- Fix the cable at a convenient location with cable clamp.
- When the cable is led in through the transom board, make a hole of approx. 17 mm diameter to pass the connector. After passing the cable, fill the hole with a sealing compound.

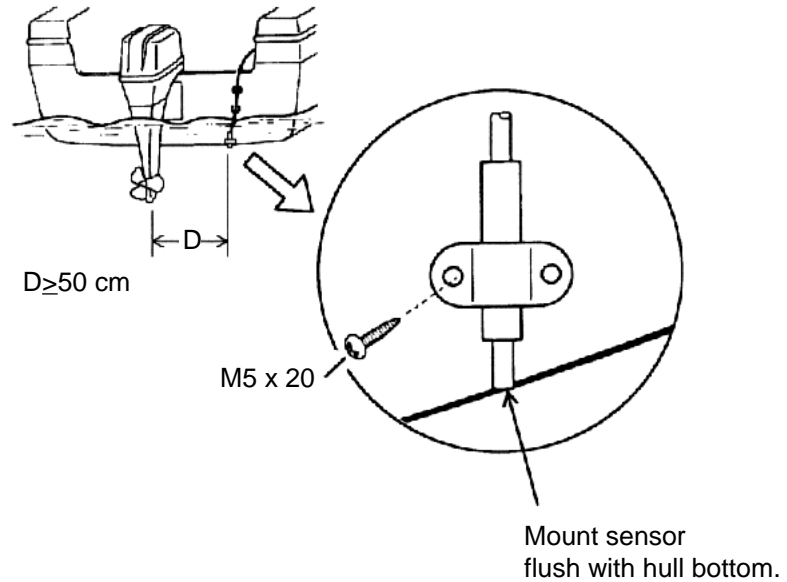

Figure 1-20 How to install transom mount water temperature sensor T-02MTB

Thru-hull mount water temperature sensor T-02MSB, T-03MSB

- Select a mid-boat flat position. The sensor does not have to be installed perfectly perpendicular. The sensor must not be damaged in dry-docking operation.
- Select a place apart from equipment generating heat.
- Select a place in the forward direction viewing from the drain hole, to allow for circulation of cooling water.
- Select a place free from vibration.

Install the sensor as shown in Figure 1-21.

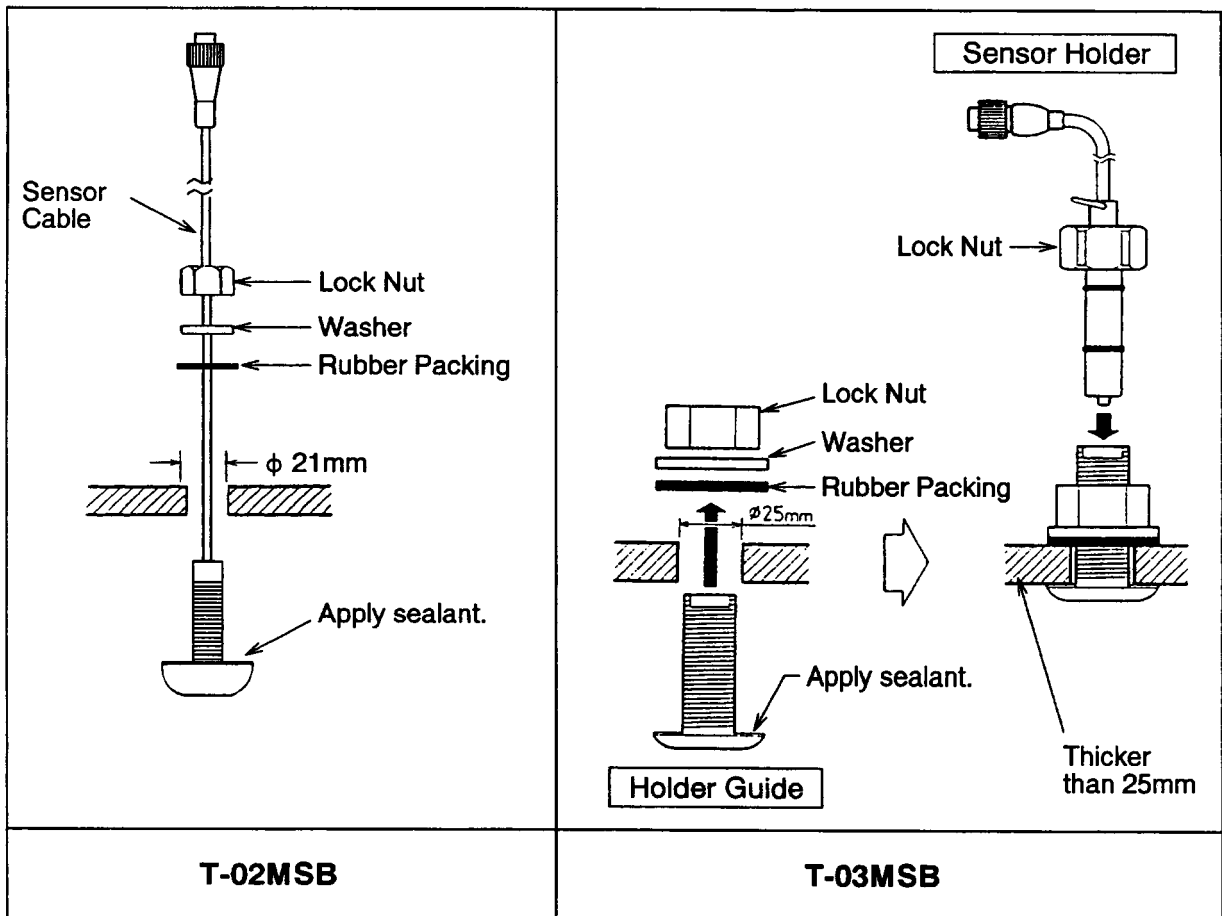

Figure 1-21 Thru-hull mount water temperature sensors
T-02MSB, T-03MSB

Through-hull mount water temperature/speed sensor ST-02MSB, ST-02PSB

Select a suitable mounting location considering the following:

- Select a mid-boat flat position. The sensor does not have to be installed perfectly perpendicular. The sensor must not be damaged in dry-docking operation.
- Select a place apart from equipment generating heat.
- Select a place in the forward direction viewing from the drain hole, to allow for circulation of cooling water.
- Select a place free from vibration.

1. Dry-dock the boat.
2. Make a hole of approx. 51 mm diameter.
3. Unfasten locknut and remove the sensor section.
4. Apply high-grade sealant to the flange of the sensor.
5. Pass the sensor casing through the hole.
6. Face the notch on the sensor toward boat's bow and tighten the flange.
7. Set the sensor section to the sensor casing and tighten the locknut.
8. Launch the boat and check for water leakage around the sensor.

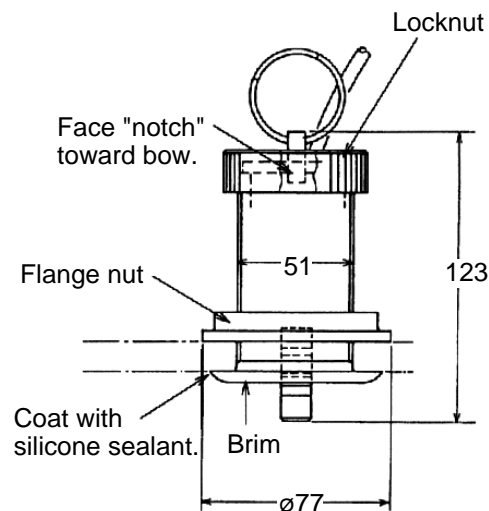

Figure 1-22 Water temperature/speed sensor ST-02MSB, ST-02PSB

2. Wiring

All wiring are terminated at the rear of the display unit.

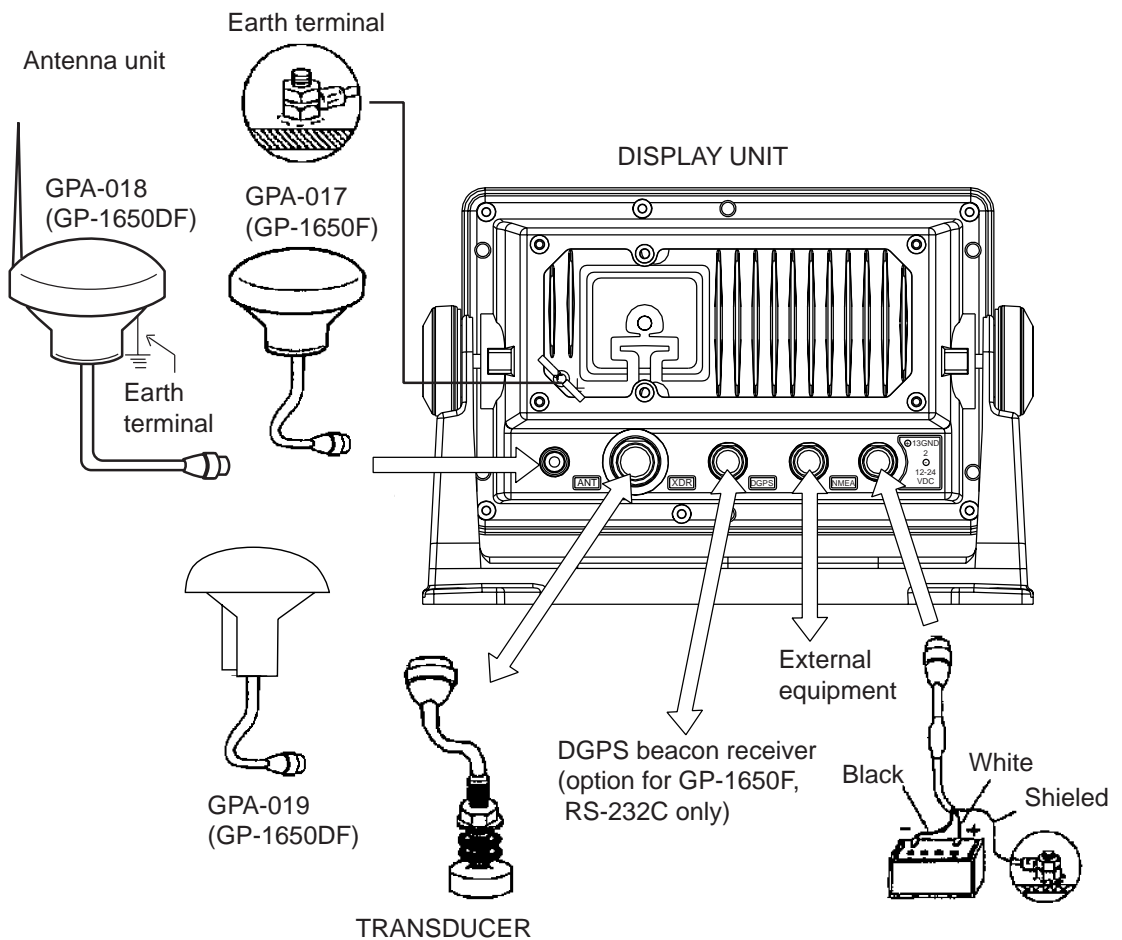

Figure 2-1 Display unit, rear view

Power cable

Connect the power cable to the power connector. Connect the leads to the battery (12 or 24 VDC); white to plus(+) terminal and black to minus(-) terminal.

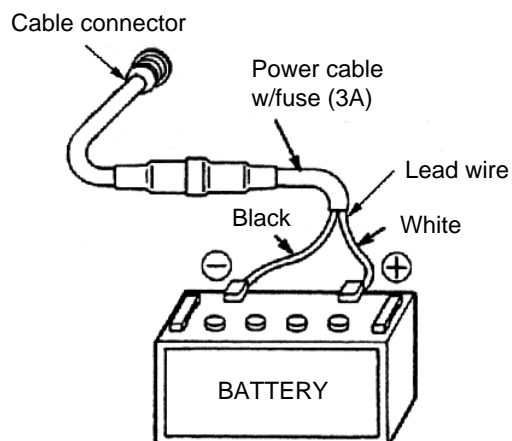

Figure 2-2 Connecting the power cable to the battery

Antenna unit

Connect the antenna unit cable to the ANT connector.

Transducer

Connect the transducer cable to the XDR connector. Connect the water temperature sensor (option) or water temperature/speed sensor (option) to the XDR connector with the converter connector (Type : 02S4147, Code No. : 000-141-082, option).

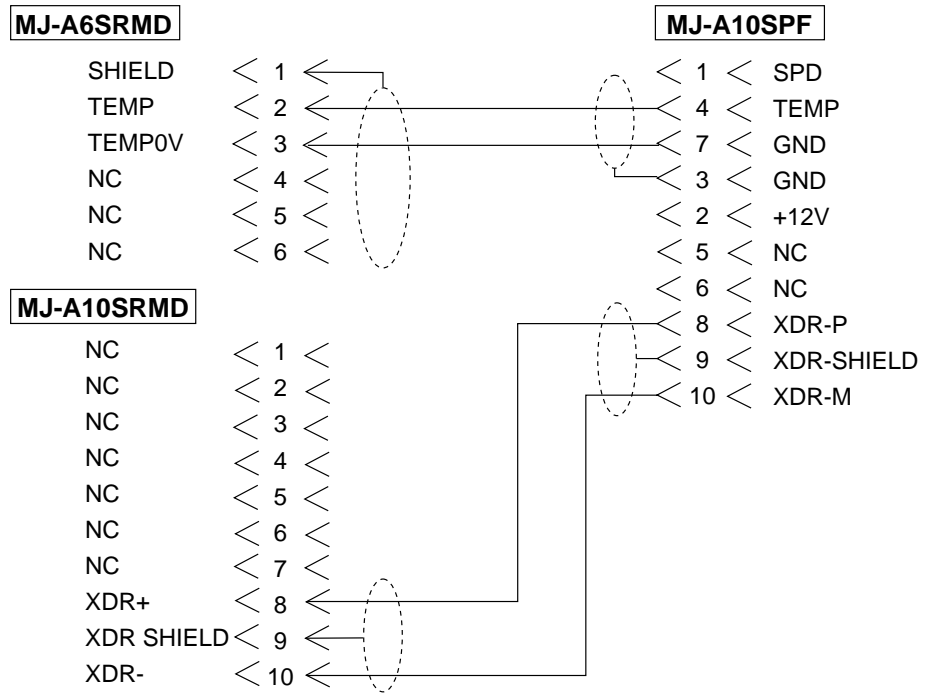

Figure 2-3 Wiring of converter connector for water temperature sensor

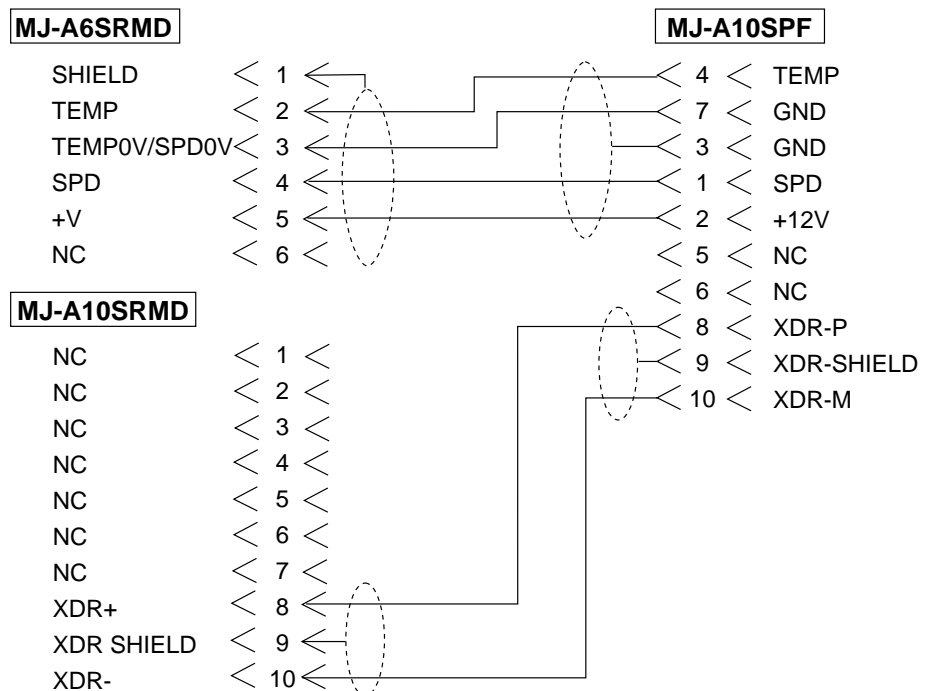

Figure 2-4 Wiring of converter connector for water temperature/speed sensor

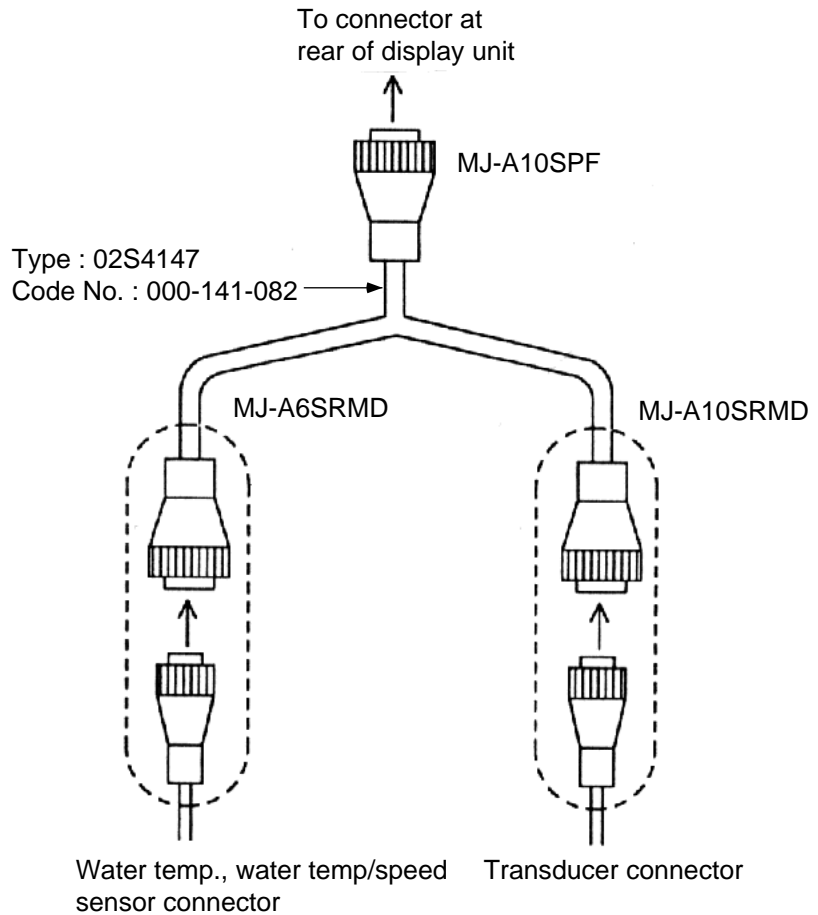

Figure 2-5 Connection of transducer, water temperature sensor, water temperature/speed sensor

Ground

The display unit contains several CPUs. While they are operating, they radiate noise, which can interfere with radio equipment. Ground the unit to

	CAUTION
	Ground the equipment to prevent electrical shock and mutual interference.

prevent interference. The grounding wire should be 1.25 sq or larger and as short as possible. Connect the grounding wire to ship's ground. On a fiberglass boat, it is best to install a ground plate that measures about 20 cm by 30 cm on the outside of the hull bottom to provide a ground point. If this is not practical, the engine block can be used. Also, the antenna unit GPA-018S(option) is required to ground with IV-1.25 sq cable as short as possible.

Note: Use a "closed" lug to make the ground connection at the display unit. Do not use an "open-type" lug ().

Extending antenna cable length

The standard cable is 10m long. For extension, in case of the GPA-016, GPA-018S or GPA-019S, an antenna cable set of 30m or 50m is available.

◆ Extension cable line-up

Fabricate the end of the antenna cable and attach the coaxial connector. Details are shown on next page.

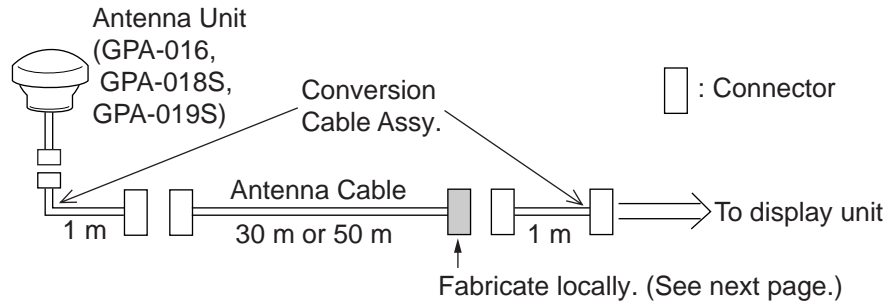

Figure 2-6 Cable extension

◆ Waterproofing connector

Wrap connector with vulcanizing tape and then vinyl tape. Bind the tape end with cable-tie.

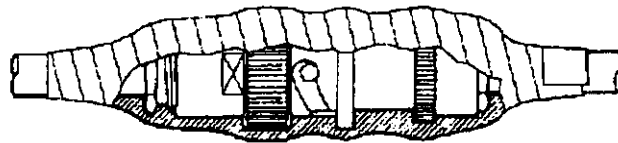
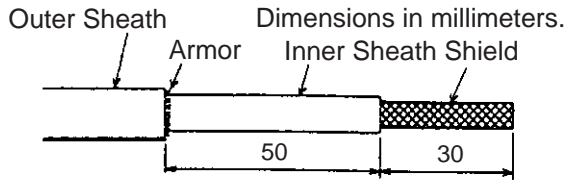
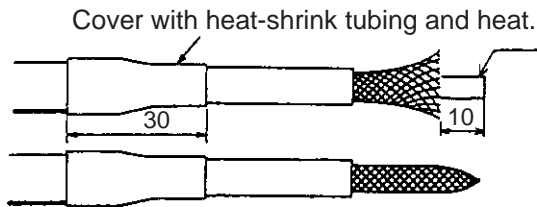

Figure 2-7 Waterproofing connector

How to attach the N-P-8DFB connector



Remove outer sheath and armor by the dimensions shown left.
Expose inner sheath and shield by the dimensions shown left.



Cut off insulator and core by 10mm.

Twist shield end.

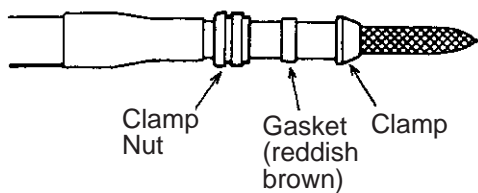

Slip on clamp nut, gasket and clamp as shown left.

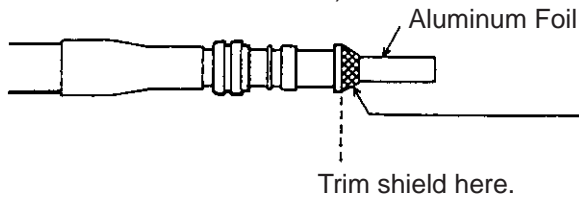

Fold back shield over clamp and trim.



Cut aluminum foil at four places, 90° from one another.

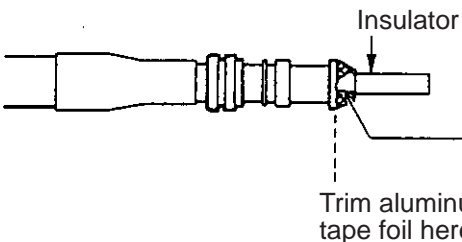

Fold back aluminum foil onto shield and trim.



Expose the insulator by 1mm.

Expose the core by 5mm.

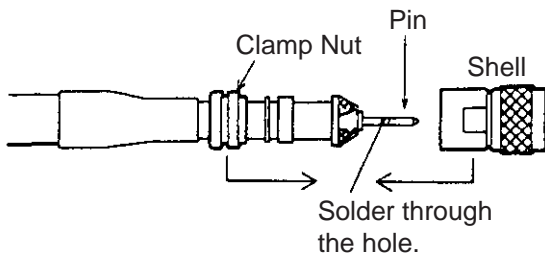

Slip the pin onto the conductor. Solder them together through the hole on the pin.

Insert the pin into the shell. Screw the clamp nut into the shell.
(Tighten by turning the clamp nut. Do not tighten by turning the shell.)

Figure 2-8 Fabrication of coaxial cable

3. Initial Settings

3.1 NMEA Setting

NMEA port

1. Press the [MENU] key.
2. Press the software key labeled "CONFIGURATION".
3. Press the software key labeled "SETUP NMEA PORT1".
4. Select "FORMAT" by the arrow key.
5. Press the software key labeled "EDIT" to display the following message.

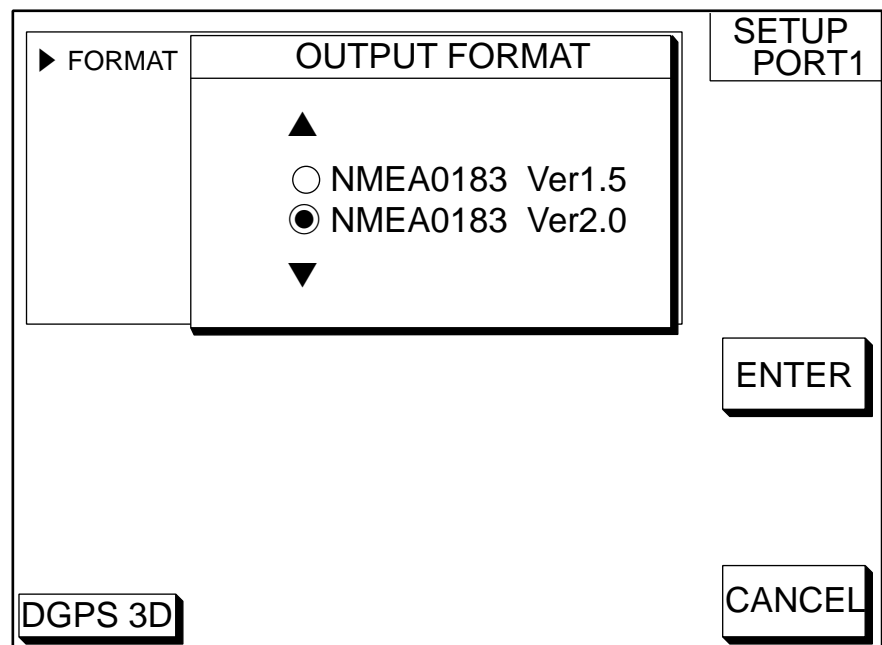

Figure 3-1 Output Format Display

6. Select NMEA version by the arrow key. The selected item is indicated by black button.
7. Press the software key labeled "ENTER".
8. Press the [PLOT] key to finish.

DGPS port

1. Press the [MENU] key.
2. Press the software key labeled "CONFIGURATION".
3. Press the software key labeled "SETUP NMEA/DGPS PORT2".
4. Select "FORMAT" by the arrow key.
5. Press the software key labeled "EDIT" to display the following message.

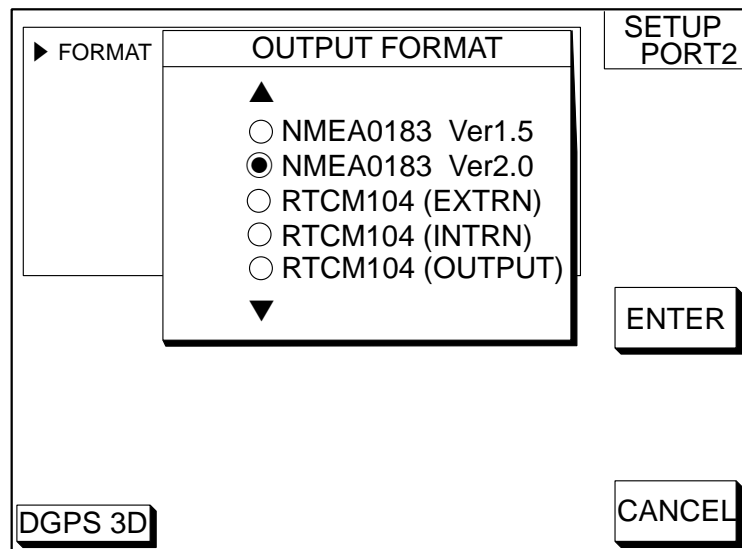

Figure 3-2 Output Format Display

6. Select NMEA version, external DGPS or internal DGPS by the arrow key. The selected item is indicated by black button.

NMEA0183 Ver1,5/Ver2,0	:Select one when connecting PC or RS-232C equipment.
RTCM104(EXTRN)	:Select this when connecting external DGPS beacon receiver.
RTCM104(INTRN)	: Select this for builtin internal DGPS beacon receiver.
RTCM104(OUTPUT)	:Select this when outputting differential data of the internal DGPS beacon receiver to other GPS navigator.

Note1) Note that you cannot setup sentences when you select RTCM104 at the format.

Note2) For RS-422 format, the level converter (IF-1432) is required for connection of external equipment.

7. Press the software key labeled "ENTER" or the [ENTER] key.
8. Press the [PLOT] key to finish.

3.2 Output Data Sentences

Select output data sentences for external equipment as follows.

1. Press the [MENU] key.
2. Press the software key labeled "CONFIGURATION".
3. Press the software key labeled "SETUP NMEA PORT1".
4. Press the software key labeled "SELECT SNTNC." to display the following list.

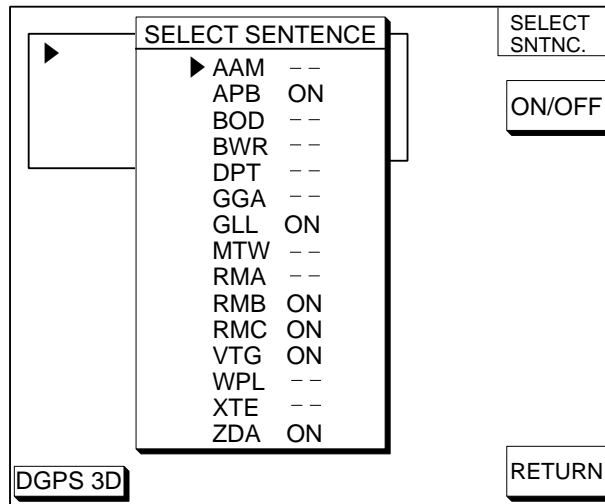

Figure 3-3 Output Date Sentences Display

5. Select data sentence you want to output data by the arrow key.
6. Press the software key labeled "ON/OFF". To output data, set to "ON".
7. Repeat to select other sentences.
8. Press the software key labeled "RETURN".
9. Press the [PLOT] key to finish.

Input/Output Sentences

Port		Format	Data	Remarks
1	Input	NMEA-0183 Ver. 2.0 Ver. 1.5	TLL*1, DWM, MTW, WPL*1	WPL : GP only MTW: TEMP SOURCE (NMEA) only
	Output		AAM, APB, BOD, BWC/BWR, GGA, GLL, RMA, RMB, RMC, VTG, WPL, XTE, ZDA, DBT/DPT, MTW, GTD*2	GREAT CIRCLE: BWC RHUMB LINE: BWR NMEA Ver 1.5: DBT NMEA Ver 2.0: DPT
2	Input		TLL*1, MTW, WPL*1	WPL: GP only MTW: TEMP SOURCE (NMEA) only
	Output		AAM, APB, BOD, BWC/BWR, GGA, GLL, RMA, RMB, RMC, VTG, WPL, XTE, ZDA, DBT/DPT, MTW, GTD*2	GREAT CIRCLE: BWC RHUMB LINE: BWR NMEA Ver 1.5: DBT NMEA Ver 2.0: DPT RS-232C

*1: Cannot be input consecutively.

*2: Output automatically when LC or LA is selected.

3.3 Antenna Height

1. Press the [MENU] key.
2. Press the software key labeled "GPS/DGPS/TD OPTIONS".
3. Press the software key labeled "GPS SETUP OPTIONS".
4. Select "ANT. HEIGHT" by the arrow key.
5. Press the software key labeled "EDIT" to display the following message.

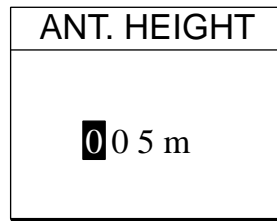

Figure 3-4 Antenna Height Display

6. Enter the height (3 digits) of the antenna above sea level using the numeric keys.

If you enter wrong antenna height, press the software key labeled "CLEAR".
7. Press the [ENTER] key.
8. Press the [PLOT] key to finish.

3.4 Baud Rate Setting (GP-1650DF only)

1. Press the [MENU] key.
2. Press the software key labeled "GPS/DGPS/TD OPTIONS".
3. Press the software key labeled "DGPS SETUP OPTIONS" to display the following message.

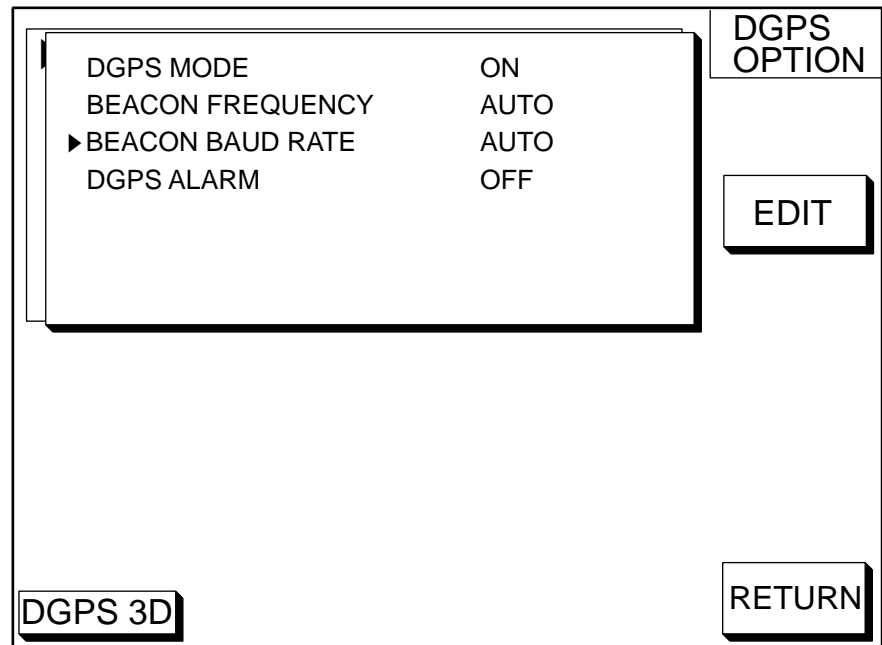

Figure 3-5 DGPS Setup Options Display

4. Confirm that "ON" is selected at "DGPS MODE" field for GP-1650DF.
5. Select "BEACON BAUD RATE" by the arrow key.
6. Press the software key labeled "EDIT" to display the following message. Beacon baud rate cannot be set when "BEACON FREQUENCY" is set to "AUTO".

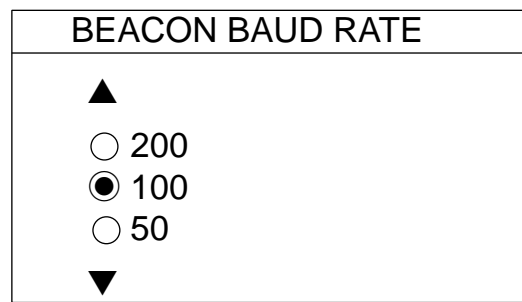

Figure 3-6 Beacon Baud Rate Display

7. Select beacon baud rate corresponding to DGPS reference station to use.
8. Press the [ENTER] key.
9. Press the [PLOT] key to finish.

3.5 Beacon frequency Setting (GP-1650DF only)

1. Press the [MENU] key.
2. Press the software key labeled "GPS/DGPS/TD OPTIONS".
3. Press the software key labeled "DGPS SETUP OPTIONS" to display the following message.

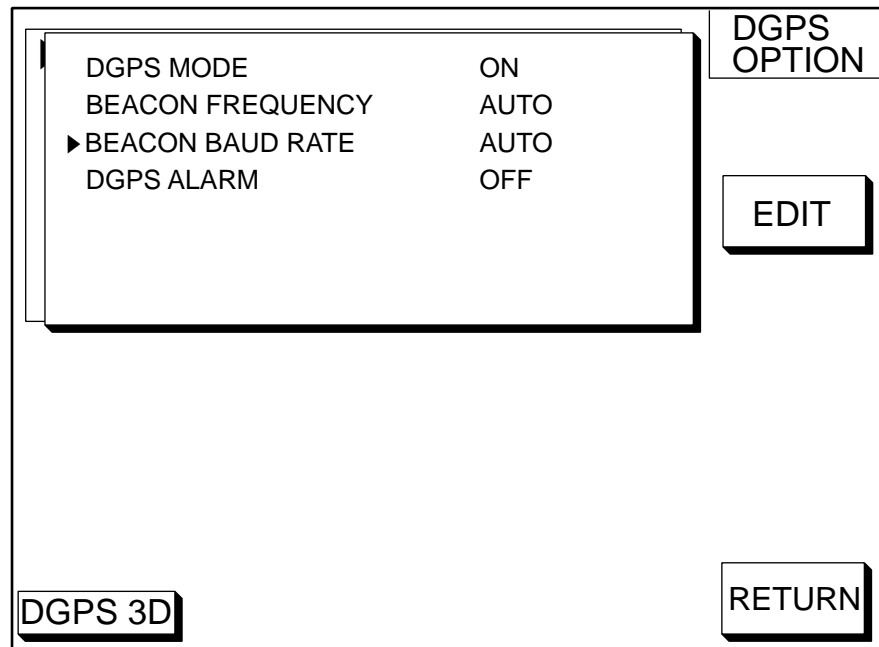

Figure 3-7 DGPS Setup Options Display

4. Select "BEACON FREQUENCY" by the arrow key.
5. Press the software key labeled "EDIT" to display the following message.

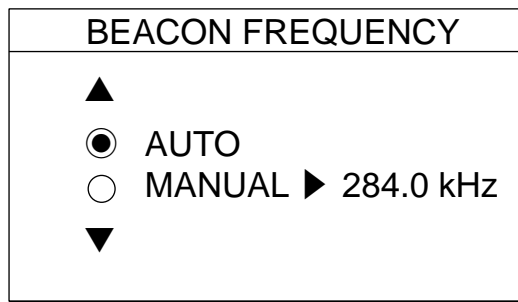

Figure 3-8 Beacon Frequency Display

6. Select "AUTO" or "MANUAL" by the arrow key. When you select "MANUAL", operate the cursor pad to move the cursor to frequency dialog box. And press the arrow key to select the frequency desired.
7. Press the [ENTER] key.
8. Press the [PLOT] key to finish.

3.6 Depth Adjustment

1. Press the [MENU] key.
2. Press the software key labeled "DISPLAY OPTION".
3. Press the software key labeled "NEXT PAGE".
4. Select "DEPTH ADJ." by the arrow key.
5. Press the software key labeled "EDIT" to display the following message.

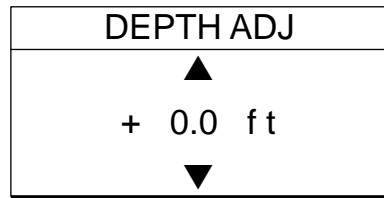

Figure 3-9 Depth Adjustment Display

6. Set depth adjustment by the arrow key. The adjustment range is -9.9~+9.9 ft.

For example, if the depth readout is 5 feet lower than actual depth, enter +5 feet.

7. Press the software key labeled "RETURN".
8. Press the [PLOT] key to finish.

3.7 External Equipment Setup (Option)

This section shows you how to set up the GP-1650F/1650DF when external equipment is connected. If a water temperature/speed sensor is installed, you should complete this section with the boat in the water and running, to confirm speed/water temperature readout.

Speed Source

1. Press the [MENU] key.
2. Press the software key labeled "DISPLAY OPTIONS".
3. Press the software key labeled "NEXT PAGE" to display the following display.

▶ SPEED SOURCE		GPS	DISPLAY SETUP2
TEMP SOURCE		OWN XDCR	
TEMP GRAPH		OFF	
ZOOM MARKER		OFF	
SPEED ADJ.		+00%	
TEMP ADJ.		+00.0°F	
DEPTH ADJ.		+0.0ft	
SPD	TEMP	DEPTH	EDIT
12.3kt	62.5°F	2000.0ft	
DGPS 3D			RETURN

Figure 3-10 Display Setup 2 Display

4. Select "SPEED SOURCE" by the arrow key.
5. Press the software key "EDIT" to display the following message.

SPEED SOURCE	
▲	
○	OWN PDDWHL
●	GPS
▼	

Figure 3-11 Speed Source Display

6. Select source of speed by the arrow key; "OWN PDDWHL" (speed sensor) or "GPS". The selected item is indicated by black button.
Adjust speed when you select "OWN PDDWHL". Refer to next page.
7. Press the software key labeled "ENTER".
8. Press the [PLOT] key to finish.

Speed Adjustment

Adjust speed when you select own speed source "OWN PDDWHL".

1. Press the [MENU] key.
2. Press the software key labeled "DISPLAY OPTIONS".
3. Press the software key labeled "NEXT PAGE" to display the following display.

▶ SPEED SOURCE		GPS	DISPLAY SETUP2
TEMP SOURCE		OWN XDCR	
TEMP GRAPH		OFF	
ZOOM MARKER		OFF	
SPEED ADJ.		+00%	
TEMP ADJ.		+00.0°F	
DEPTH ADJ.		+0.0ft	
SPD	TEMP	DEPTH	
12.3kt	62.5°F	2000.0ft	
DGPS 3D			EDIT
			RETURN

Figure 3-12 Display Setup 2 Display

4. Select "SPEED ADJ." by the arrow key.
5. For speed sensor-equipped sets, you may offset the speed readout if it is wrong. Run the boat at various speeds and watch the speed readout at the bottom of the screen. If it is unreasonably wrong, press the software key "EDIT" to display the following message.

SPEED ADJ		
▲		
+	00	%
▼		

Figure 3-13 Speed Adjustment display

6. Correct speed readout by the arrow key. The adjustment range is -50%~+50%.
For example, if readout is 10% lower than actual speed, enter +10%.
7. Press the software key "RETURN".

8. Press the [PLOT] key to finish.

Temperature Adjustment

1. Press the [MENU] key.
2. Press the software key labeled "DISPLAY OPTIONS".
3. Press the software key labeled "NEXT PAGE" to display the following display.

▶ SPEED SOURCE		GPS	DISPLAY SETUP2
TEMP SOURCE		OWN XDGR	
TEMP GRAPH		OFF	
ZOOM MARKER		OFF	
SPEED ADJ.		+00%	
TEMP ADJ.		+00.0°F	
DEPTH ADJ.		+0.0ft	
SPD	TEMP	DEPTH	EDIT
12.3kt	62.5°F	2000.0ft	
DGPS 3D			RETURN

Figure 3-14 Display Setup 2 Display

4. Select "TEMP ADJ." by the arrow key.

4. Installation of DGPS Beacon Receiver (for GP-1650F)

The DGPS beacon receiver GR-7000A can be incorporated in the GP-1650F to provide it with DGPS capability. Six installation kits are available as shown.

GR-802-1650-10A-018
GR-802-1650-10N-018 (No whip ant.)

Name	Type	Code No.	Qty
Antenna Unit	GPA-018	000-041-471	1
Beacon Receiver	GR-7000A	000-143-249	1
Connector Assy.	PH6P-W-L240	000-141-548	1
Pan head screws	M3X10 C2700W	000-881-405	4
Cable tie	CV-100	000-570-322	2
Screw	M3X12 SUS304	000-805-905	6
Cable Assy.	S.FL2-2LP0.7-D-WHT (121)	000-141-491	1
Whip antenna (10A type only)	FAW-1.2	000-130-046	1
Clamp	HP-2N	000-570-000	1
Cable Assy.*	S.FL2-2LP0.7-D-WHT (250)	000-143-877	1
Screw*	3X8 SUS410	000-802-951	4

* Not used

GR-802-1650-15A-018S
GR-802-1650-15N-018S (No whip ant.)

Name	Type	Code No.	Qty
Antenna Unit	GPA-018S	000-041-462	1
Beacon Receiver	GR-7000A	000-143-249	1
Cable Assy.	TNC-PS-3D-15	000-133-670	1
Connector Assy.	PH6P-W-L240	000-141-548	1
Pan head screws	M3X10 C2700W	000-881-405	4
Cable tie	CV-100	000-570-322	2
Screw	M3X12 SUS304	000-805-905	6
Cable Assy.	S.FL2-2LP0.7-D-WHT (121)	000-141-491	1
Whip antenna (15A type only)	FAW-1.2	000-130-046	1
Clamp	HP-2N	000-570-000	1
Cable Assy.*	S.FL2-2LP0.7-D-WHT (250)	000-143-877	1
Screw*	3X8 SUS410	000-802-951	4

* Not used

GR-802-1650-10N-019 (No whip ant.)

Name	Type	Code No.	Qty
Antenna Unit	GPA-019	000-041-552	1
Beacon Receiver	GR-7000A	000-143-249	1
Connector Assy.	PH6P-W-L240	000-141-548	1
Pan head screws	M3X10 C2700W	000-881-405	4
Cable tie	CV-100	000-570-322	2
Screw	M3X12 SUS304	000-805-905	6
Cable Assy.	S.FL2-2LP0.7-D-WHT (121)	000-141-491	1
Clamp	HP-2N	000-570-000	1
Cable Assy.*	S.FL2-2LP0.7-D-WHT (250)	000-143-877	1
Screw*	3X8 SUS410	000-802-951	4

* Not used

GR-802-1650-15N-019S (No whip ant.)

Name	Type	Code No.	Qty
Antenna Unit	GPA-019S	000-041-554	1
Beacon Receiver	GR-7000A	000-143-249	1
Cable Assy.	TNC-PS-3D-15	000-133-670	1
Connector Assy.	PH6P-W-L240	000-141-548	1
Pan head screws	M3X10 C2700W	000-881-405	4
Cable tie	CV-100	000-570-322	2
Screw	M3X12 SUS304	000-805-905	6
Cable Assy.	S.FL2-2LP0.7-D-WHT (121)	000-141-491	1
Clamp	HP-2N	000-570-000	1
Cable Assy.*	S.FL2-2LP0.7-D-WHT (250)	000-143-877	1
Screw*	3X8 SUS410	000-802-951	4

* Not used

Disassembly

Procedure

1. Turn off the power. Wait at least one minute before opening the cover, to allow capacitors to discharge.
2. Remove nuts attached to DGPS, NMEA and power supply connectors at the rear of the display unit.

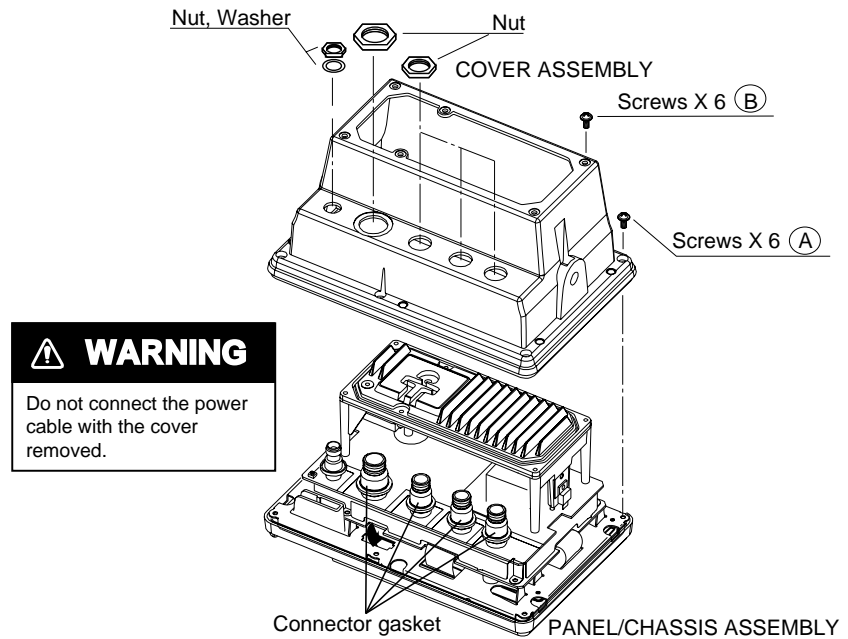

Figure 4-1 Removing cover assembly

3. Remove nuts and washer attached to ANT connector.
4. Remove twelve screws at rear of the display unit to detach panel/chassis assembly from cover assembly. Discard six screws (A) (3X12).

Installation of DGPS receiver

Procedure

1. Disconnect 8P connector as shown in the figure below.

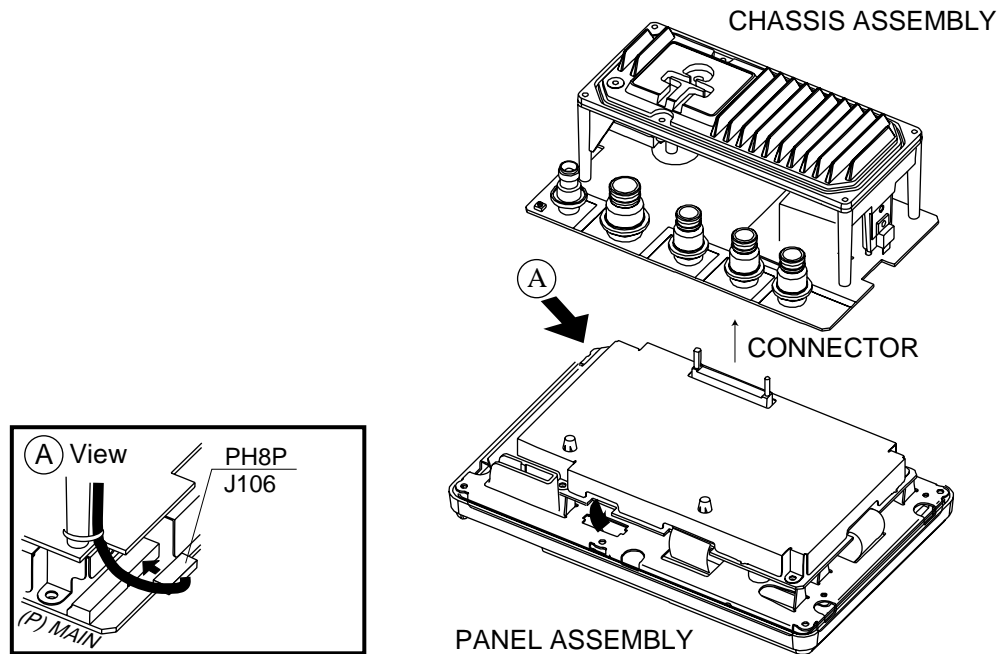

Figure 4-2 Dismounting chassis assembly

2. Dismount chassis assembly from panel assembly by disconnecting connector shown in the figure above.
3. Cut the cable ties as shown in the figure below.

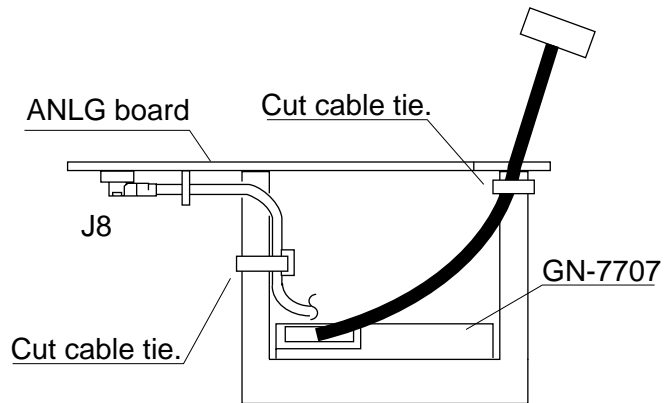

Figure 4-3 Cutting cable ties

4. Dismount heat sink from chassis assembly by unfastening four screws on the ANLG board and disconnecting the connector of the mini pin coaxial cable.

Handling of Coaxial Cable

- Do not touch the connector with bare hands; use gloves.
- Use radio pincers to remove, and pull out straightly.
- Plug in connector straightly.

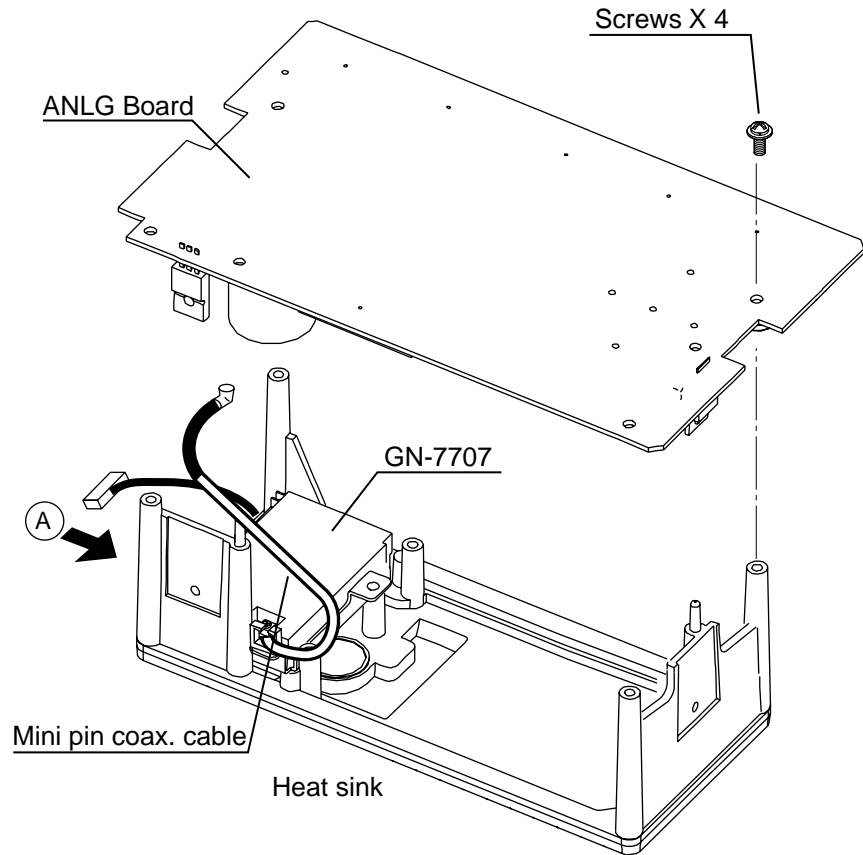

Figure 4-4 Chassis assembly

5. Take off the mini pin coaxial cable from J2 on the GN-7707.
6. Open the lid of GR-7000A.
7. Connect the mini pin coaxial cable to J1 of GN-7000A.

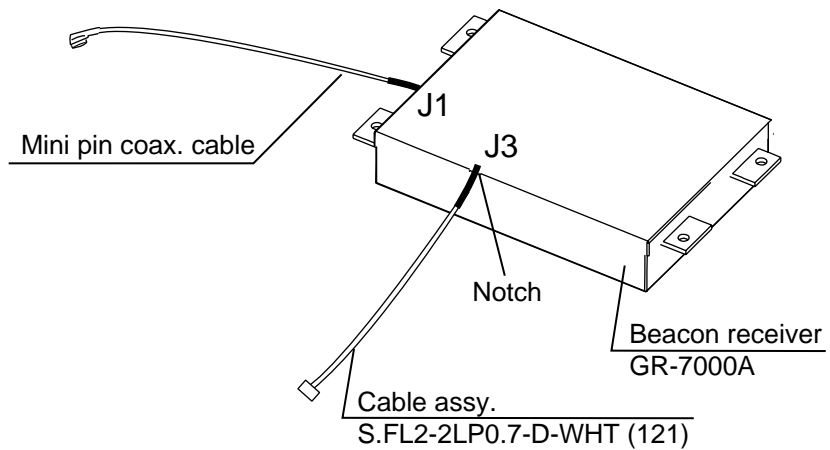

Figure 4-5 Beacon receiver

8. Connect cable assy. S.FL2-2LP0.7-D-WHT (121) (supplied) to J3 of the GR-7000A.
9. Close the lid of the GR-7000A.
10. Connect connector assy. PH6P-W-L240 to J2 of GR-7000A (Refer to Figure 4-6).
11. Fasten the GR-7000A (Beacon receiver) to the heat sink with four M3X10 screws (supplied) as shown in the figure below.

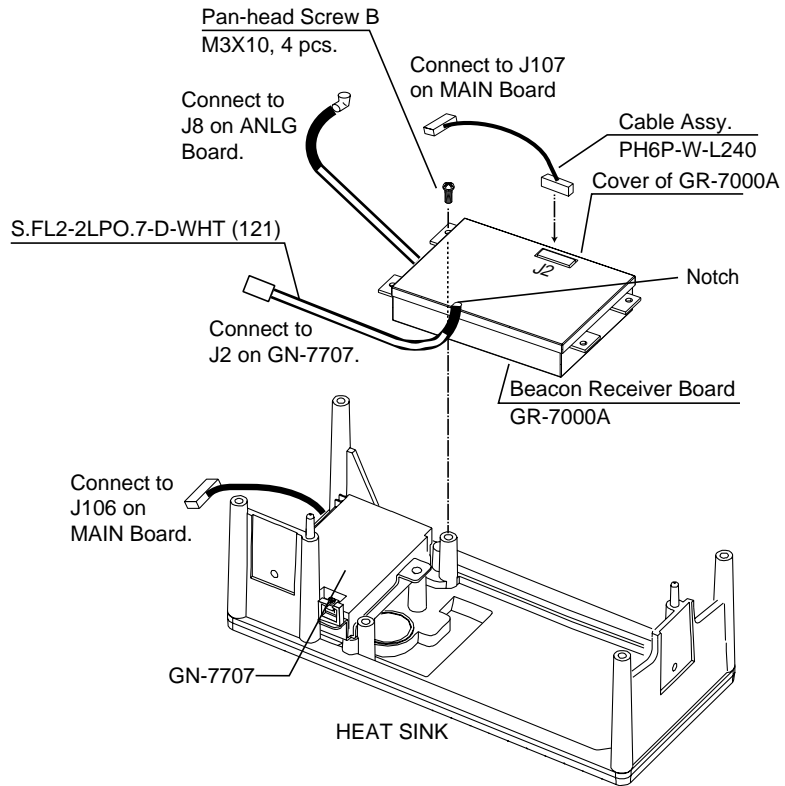

Figure 4-6 Installation of DGPS beacon receiver

12. Connect the cable assay. S.FL2-2LPO.7-D-WHT (121) of J3 to J2 of the GN-7707.
13. Pass the mini pin coaxial cable J1 on the GR-7000A through the mini plug on the ANLG Board and connect it to J8 on the ANLG Board.

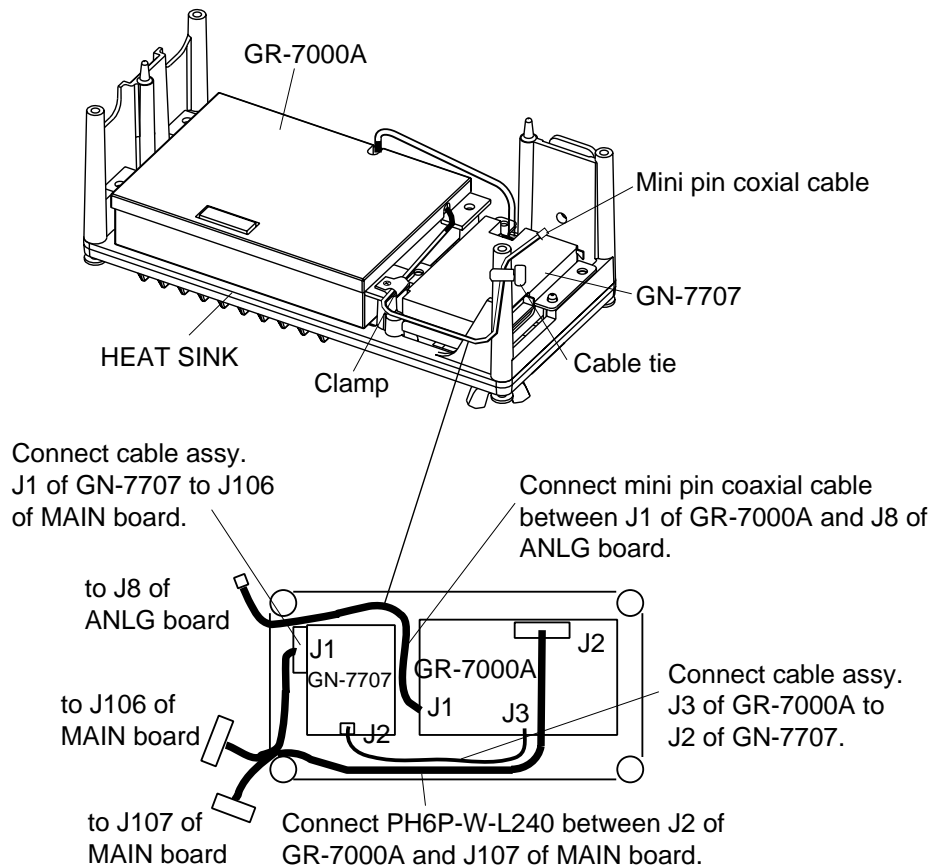

Figure 4-7 Wiring the Cable assembly

14. Mount the ANLG board on the heat sink.
15. Mount chassis assembly on the panel assembly. Connect 8P connector and 6P connector to Main board as shown in the figure below.

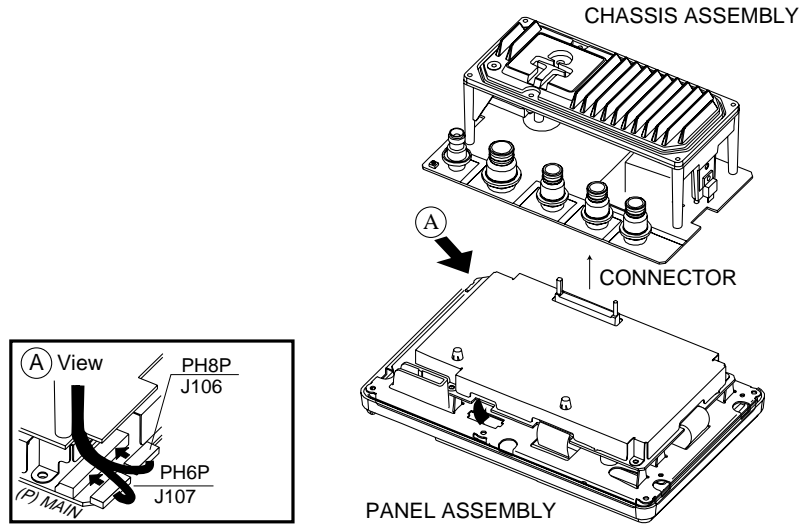

Figure 4-8 Attaching chassis assembly

16. Fasten 8P connector cable and 6P connector cable by cable tie as shown in the figure below. Fasten mini pin coaxial cable by cable tie as shown in the figure.

Note: After connecting, pull up cable to remove slack so as not to pinch the cable between cover panel assembly.

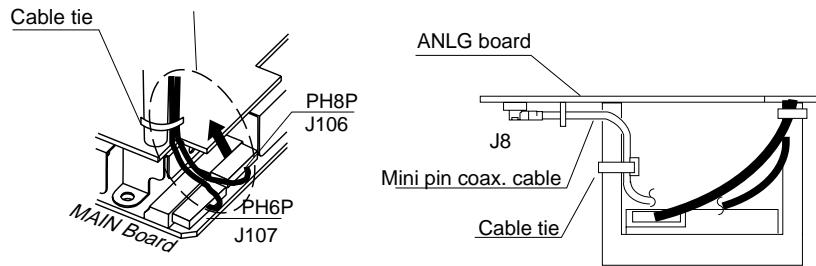

Figure 4-9 Attaching cable tie

17. Reassemble the display unit.
Use new screws size 3X12 (supplied).

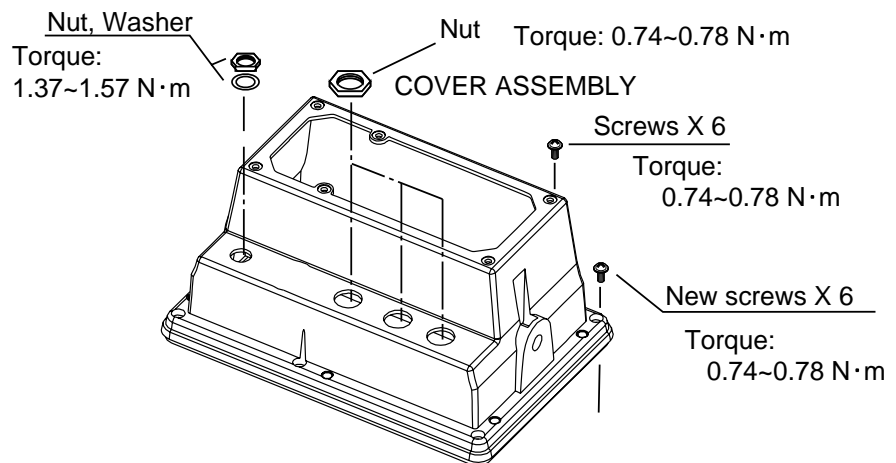

Figure 4-10 Remounting the cover

Note: When reattaching the cover, confirm the following parts are attached.

- *Shield gasket, cover gasket (See figure 4-11.)*
- *Connector gasket (See figure 4-1.)*

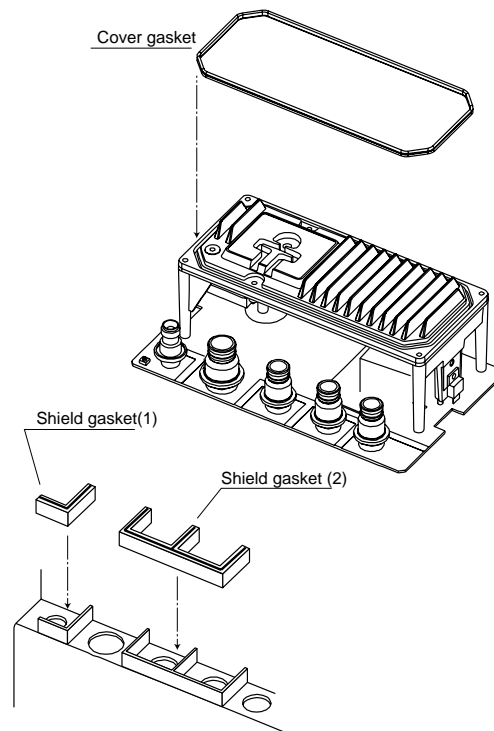
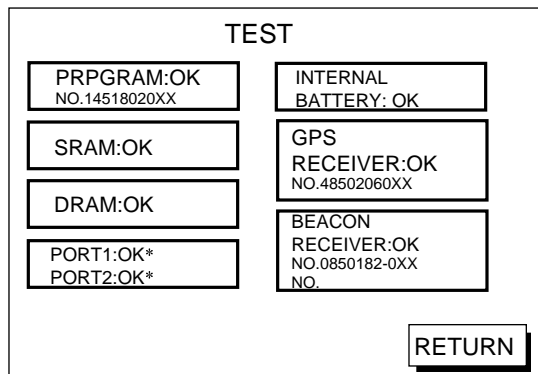

Figure 4-11 Gaskets

Checking the DGPS installation

1. Press the [MENU] key.
2. Press the software key labeled "CONFIGURATION".
3. Press the software key labeled "SYSTEM MENU".
4. Press the software key labeled "SELF TEST".
5. Press the software key labeled "MEMORY•I/O TEST" to display the following message.



*Special connections are required to check these ports. Otherwise, "--" appears.

Figure 4-12 Memory, I/O Test Display

6. Confirm that "BEACON RECEIVER: OK" is displayed.
7. Press the software key labeled "RETURN".
8. Press the [PLOT] key to return the plotter display.

Connecting DGPS beacon receiver

A DGPS beacon receiver whose output format is RS-232C can be connected to the GP-1650F.

Below is the example of interconnection between the GP-1650F and FURUNO beacon receiver GR-80.

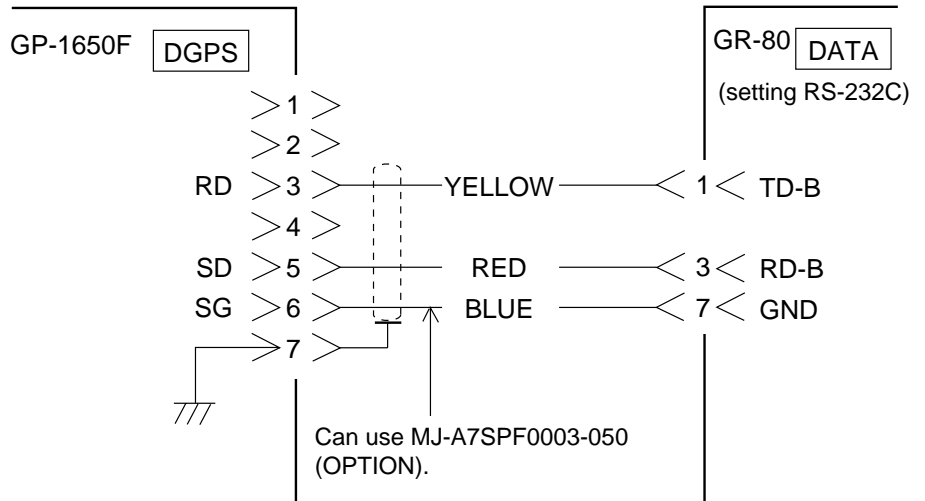

Figure 4-13 Connecting DGPS beacon receiver

APPENDIX

TRIDUCER 525ST-PWC/PWD

This appendix provides a copy of the installation instructions for AIRMAR triducer. If you lose the original supplied with the triducer, use this appendix.

INSTALLATION INSTRUCTIONS

Transom Mount Transducer or TRIDUCER® Multisensor with Integral Release Bracket

Model P66

U.S. Patents: 4,555,938; 4,644,787; 5,606,253; Des. 334,335
Canadian Patent 1,233,341

IMPORTANT Please read the instructions completely before proceeding with the installation. These directions supersede any other instructions in your instrument manual if they differ.



Applications

- Powerboats with outboard, inboard, inboard/outboard, or jet drive. Not recommended for boats with large or twin screw inboard motor.
- Bracket protects the sensor from frontal impact only
- Good operation up to 44kn (50MPH)
- Orients the sound beam vertically on hulls with a deadrise angle up to 30°
- Adjusts to transom angles from 2-22°

Tools and Materials Needed

- Scissors
- Masking tape
- Safety goggles
- Dust mask
- Electric drill
- Drill bit for:
 - Bracket holes 4mm, #23, or 9/64"
 - Fiberglass hull chamfer bit (preferred), 6mm, or 1/4"
 - Transom hole 19mm or 3/4" (optional)
 - Cable clamp holes 3mm or 1/8"
- Screwdrivers
- Straight edge
- Marine sealant
- Pencil
- Zip-ties
- Water-based antifouling paint (**mandatory in salt water**).

Pre-test for Speed and Temperature

Connect the sensor to the instrument and spin the paddlewheel. Check for a speed reading and the approximate air temperature. If there is no reading, return the sensor to your place of purchase.

Mounting Location

To ensure the best performance, the sensor *must* be submerged in aeration-free and turbulence-free water. Mount the sensor close to the centerline of the boat. On slower heavier displacement hulls, positioning it farther from the centerline is acceptable.

Allow adequate space above the bracket for it to release and rotate the sensor upward (see Figure 1).

Caution: Do not mount the sensor in an area of turbulence or bubbles: Near water intake or discharge openings; Behind strakes, struts, fittings, or hull irregularities; Behind eroding paint (an indication of turbulence).

Caution: Avoid mounting the sensor where the boat may be supported during trailering, launching, hauling, and storage.

- **Single drive boat**—Mount on the starboard side at least 75mm (3") beyond the swing radius of the propeller (see Figure 2).
- **Twin drive boat**—Mount between the drives.

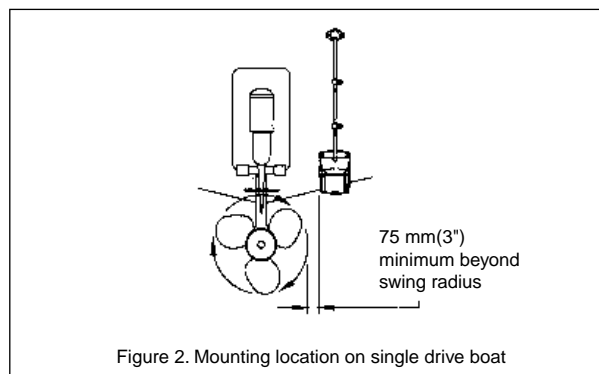
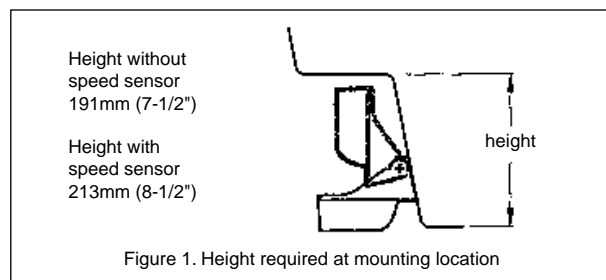

P66 Installation template
for starboard side of boat

Drill at locations labeled "B"
for the following transom angles:
16° through 22°



Drill at locations labeled "A"
for the following transom angles:
2° through 15°

Align arrow with bottom of transom

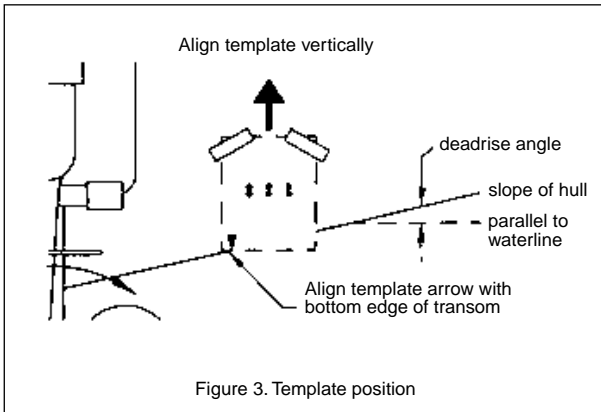

Caution: Never Use Solvents!

Cleaners, gasoline, paint, sealants, and other products may contain strong solvents such as acetone which can attack many plastics dramatically reducing their strength.

Installation

Bracket

1. Cut out the installation template shown on the left.
2. At the selected location, position the template, so the arrow at the bottom is aligned with the bottom edge of the transom. *Being sure* the template is parallel to the waterline, tape it in place (see Figure 3).

Warning: Always wear safety goggles and a dust mask.

3. Using a 4mm, #23, or 9/64" bit, drill three holes 22mm (7/8") deep at the locations indicated. To prevent drilling too deeply, wrap masking tape around the bit 22mm (7/8") from the point.
Fiberglass hull—Minimize surface cracking by chamfering the gelcoat. If a chamfer bit or countersink bit is not available, start drilling with a 6mm or 1/4" bit to a depth of 1mm (1/16").
4. **If you know your transom angle**—The bracket is designed for a standard 13° transom angle.
11°-18° angle—No shim is required. Skip to "Adjusting", step 3.
Other angles—The shim is required. Skip to "Adjusting", step 2.

If you do not know the transom angle—Temporarily attach the bracket and sensor to the transom to determine if the plastic shim is needed.

5. Using the two #10 x 1-1/4" self-tapping screws, temporarily screw the bracket to the hull. *Do not* tighten the screws completely at this time. Follow the instructions for "Attaching the Sensor to the Bracket", steps 1-4 before proceeding with "Adjusting".

Adjusting

1. Using a straight edge, sight the underside of the sensor relative to the underside of the hull. The stern of the sensor should be 1-3mm (1/16-1/8") below the bow of the sensor or parallel to the bottom of the hull (see Figure 5).

Caution: Do not position the bow of the sensor lower than the stern because aeration will occur.

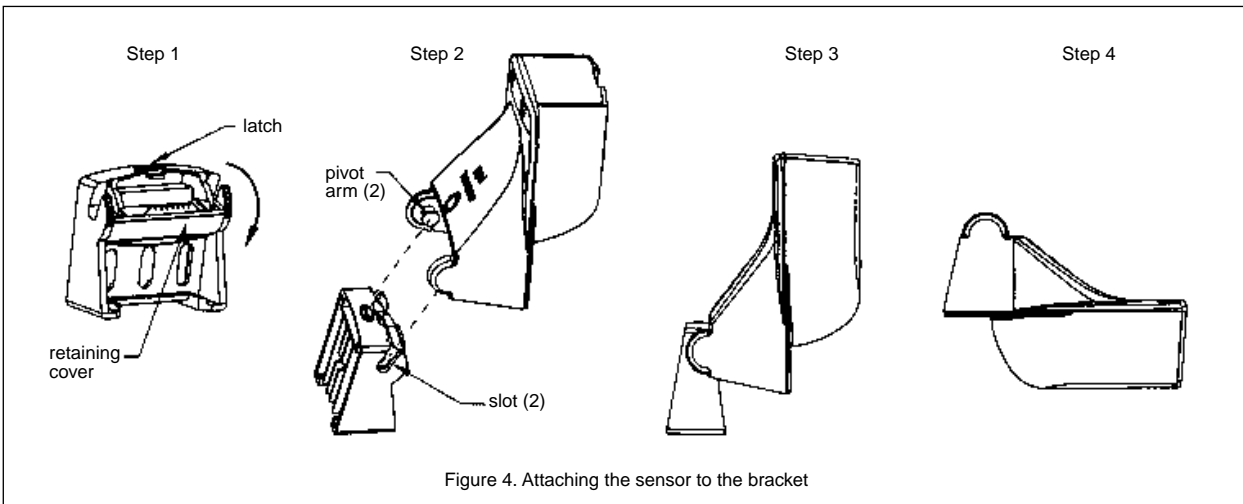

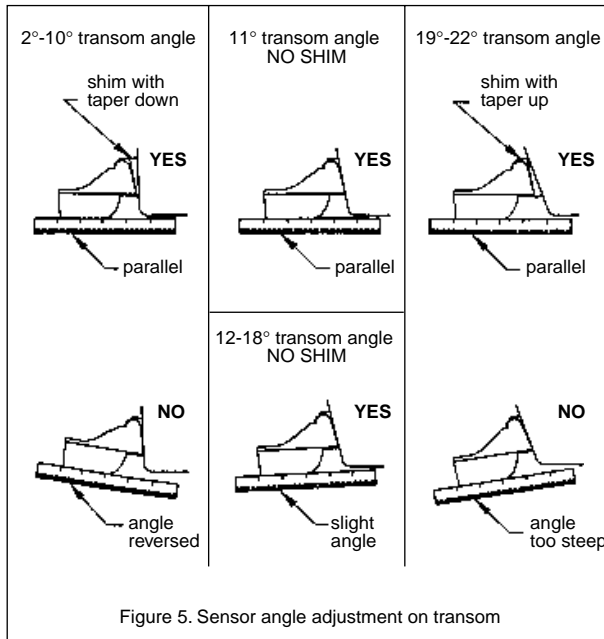

Figure 5. Sensor angle adjustment on transom

- To adjust the sensor's angle relative to the hull, use the tapered plastic shim provided. If the bracket has been temporarily fastened to the transom, remove it. Key the shim in place on the back of the bracket.
 - 2°-10° transom angle** (stepped transom and jet boats)—Position the shim with the tapered end down.
 - 19°-22° transom angle** (small aluminum and fiberglass boats)—Position the shim with the tapered end up.
- If the bracket has been temporarily fastened to the transom, remove it. Apply a marine sealant to the threads of the two #10 x 1-1/4" self tapping screws to prevent water seeping into the transom. Screw the bracket to the hull. *Do not* tighten the screws completely at this time.

- Repeat step 1 to ensure that the angle of the sensor is correct.

Caution: Do not position the sensor farther into the water than necessary to avoid increasing drag, spray, and water noise and reducing boat speed.

- Using the vertical adjustment space on the bracket slots, slide the sensor up or down to provide a projection of 3mm (1/8"). Tighten the screws (see Figure 6).

Attaching the Sensor to the Bracket

- If the retaining cover near the top of the bracket is closed, open it by depressing the latch and rotating the cover downward (see Figure 4).
- Insert the sensor's pivot arms into the slots near the top of the bracket.
- Maintain pressure until the pivot arms click into place.
- Rotate the sensor downward until the bottom snaps into the bracket.
- Close the retaining cover to prevent the accidental release of the sensor when the boat is underway.

Cable Routing

Route the sensor cable over the transom, through a drain hole, or through a new hole drilled in the transom **above the waterline**.

Caution: Never cut the cable or remove the connector; this will void the warranty.

Warning: Always wear safety goggles and a dust mask.

- If a hole must be drilled, choose a location well above the waterline. Check for obstructions such as trim tabs, pumps, or wiring inside the hull. Mark the location with a pencil. Drill a hole through the transom using a 19mm or 3/4" bit (to accommodate the connector).
- Route the cable over or through the transom.
- On the outside of the hull secure the cable against the transom using the cable clamps. Position a cable clamp 50mm(2") above the bracket and mark the mounting hole with a pencil (see Figure 6).
- Position the second cable clamp halfway between the first clamp and the cable hole. Mark this mounting hole.
- If a hole has been drilled in the transom, open the appropriate slot in the transom cable cover. Position the cover over the cable where it enters the hull. Mark the two mounting holes.
- At each of the marked locations, use a 3mm or 1/8" bit to drill a hole 10mm (3/8") deep. The prevent drilling too deeply, wrap masking tape around the bit 10mm (3/8") from the point.
- Apply marine sealant to the threads of the #6 x 1/2" self-tapping screw to prevent water from seeping into the transom. If you have drilled a hole through the transom, apply marine sealant to the space around the cable where it passes through the transom.
- Position the two cable clamps and fasten them in place. If used, push the cable cover over the cable and screw it in place.
- Route the cable to the instrument being careful not to tear the cable jacket when passing it through the bulkhead(s) and other parts of the boat. To reduce electrical interference, separate the sensor cable from other electrical wiring and "noise" sources. Coil any excess cable and secure it in place with zip-ties to prevent damage.
- Refer to your echosounder owner's manual to connect the sensor to the instrument.

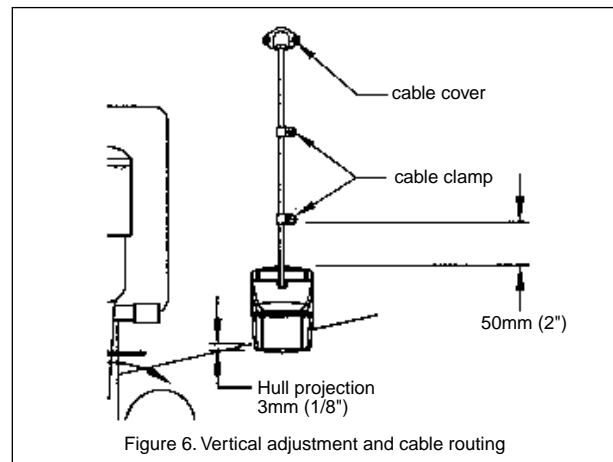

Figure 6. Vertical adjustment and cable routing

PACKING LIST GP-1650/1650F (E017)

14CE-X-9854-2 1/1

NAME	OUTLINE	DESCRIPTION/CODE No.	Q'TY
ユニット			
指示器		GP-1650-E	1
DISPLAY UNIT		000-041-476**	
空中線部		GPA-017	1
ANTENNA UNIT		000-041-403	

予備品 SPARE PARTS SP14-02401

ヒューズ		FG80-A 3A AC125V	3
FUSE		000-549-063	

付属品 ACCESSORIES FP14-02302

+トラスレット・ナット		5X16 SUS304 1種	4
+TAPPING SCREW		000-805-494	
+ナット・ワッシャー・B		MAX20 SUS304	6
WASHER HEAD SCREW		000-804-742	

付属品 ACCESSORIES FP14-02301

ハードカバー組品		FP14-02301	1
HARD COVER ASSY.		004-375-830	

その他工材 OTHER INSTALLATION MATERIALS

NAME	OUTLINE	DESCRIPTION/CODE No.	Q'TY
ケーブル組品MJ		MJ-A3SPF0013-035	1
POWER CABLE		000-135-397	
ケーブル組品MJ		MJ-A6SPF0003-050	1
CABLE ASSY.		000-117-603	

注記) コード末尾に[*]の付いたユニットは代表の型式/コードを表示しています。
 DOUBLE ASTERISK DENOTES COMMONLY USED EQUIPMENT.
 2.送受信器他オプション等は別梱包になります。
 OPTIONS, FOR EXAMPLE TRANSDUCER ARE SUPPLIED IN OTHER BOX.

(略図の寸法は、参考値です。 DIMENSIONS IN DRAWING FOR REFERENCE ONLY.)

DWG NO. C4394-Z06-A
 A-1

PACKING LIST GP-1650D/1650DF (E018)

14CE-X-9852-5 1/1

NAME	OUTLINE	DESCRIPTION/CODE No.	Q'TY
ユニット UNIT			
空中線部		GPA-018	1
ANTENNA UNIT		000-041-407	
指示器		GP-1650D-E	1
DISPLAY UNIT		000-041-477**	

予備品 SPARE PARTS SP14-02401

ヒューズ		FGBO-A 3A AC125V	3
FUSE		000-549-063	

付属品 ACCESSORIES FP14-02302

+ナット M4X20 B		M4X20 SUS304	6
WASHER HEAD SCREW		000-804-742	
+トラスタップ・ソケット		5X16 SUS304 1種	4
+TAPPING SCREW		000-805-494	

付属品 ACCESSORIES FP14-02301

ハードカバー組品		FP14-02301	1
HARD COVER ASSY.		004-375-830	

その他工材 OTHER INSTALLATION MATERIALS

NAME	OUTLINE	DESCRIPTION/CODE No.	Q'TY
ケーブル組品MJ		MJ-A3SPF0013-035	1
POWER CABLE		000-135-397	
ケーブル組品MJ		MJ-A6SPF0003-050	1
CABLE ASSY.		000-117-603	

注記) コード末尾に[*]の付いたユニットは代表の型式/コードを表示しています。
 DOUBLE ASTERISK DENOTES COMMONLY USED EQUIPMENT.
 2.ホイップアンテナ、送受信機他オプション等は別梱包になります。
 OPTIONS, FOR EXAMPLE WHIP ANTENNA, TRANSDUCER ARE SUPPLIED IN OTHER BOX.

(略図の寸法は、参考値です。 DIMENSIONS IN DRAWING FOR REFERENCE ONLY.)

DWG NO. C4394-Z02-C

A-2

PACKING LIST GP-1650D/1650DF (E019)

14CE-X-9856-3 1/1

NAME	OUTLINE	DESCRIPTION/CODE No.	Q'TY
ユニット UNIT			
指示器		GP-1650D-E	1
DISPLAY UNIT		000-041-477**	
空中線部		GPA-019	1
ANTENNA UNIT		000-142-416	

予備品 SPARE PARTS SP14-02401

ヒューズ		FG80-A 3A AC125V	3
FUSE		000-549-063	

付属品 ACCESSORIES FP14-02302

+トラスヘッドネジ		5X16 SUS304 1種	4
+TAPPING SCREW		000-805-494	
+ワッシャーネジ B		M4X20 SUS304	6
WASHER HEAD SCREW		000-804-742	

付属品 ACCESSORIES FP14-02301

ハードカバー組品		FP14-02301	1
HARD COVER ASSY.		004-375-830	

その他工材 OTHER INSTALLATION MATERIALS

NAME	OUTLINE	DESCRIPTION/CODE No.	Q'TY
ケーブル組品MJ		MJ-A3SPF0013-035	1
POWER CABLE		000-135-397	
ケーブル組品MJ		MJ-A6SPF0003-060	1
CABLE ASSY.		000-117-603	



注記) コード末尾に[**]の付いたユニットは代表の型式/コードを表示しています。
 DOUBLE ASTERISK DENOTES COMMONLY USED EQUIPMENT.
 2.送受信機他オプション等は別梱包になります。
 OPTIONS, FOR EXAMPLE TRANSDUCER ARE SUPPLIED IN OTHER BOX.

(略図の寸法は、参考値です。 DIMENSIONS IN DRAWING FOR REFERENCE ONLY.)

DWG NO. C4394-Z04-B

PACKING LIST

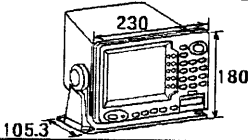
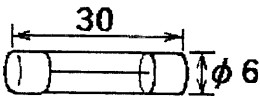
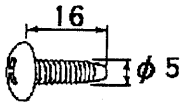
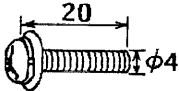
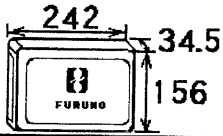
GP-1650D/1650DF (E/J)

NAME	OUTLINE	DESCRIPTION/CODE No.	QTY
ユニット UNIT			
指示器 DISPLAY UNIT		GP-1650D-J 000-041-541 **	1
予備品 SPARE PARTS		SP14-02401	
ヒューズ FUSE		FGBO-A 3A AC125V 000-549-063	3
付属品 ACCESSORIES		FP14-02302	
+トラスタップ・ソネジ +TAPPING SCREW		5X16 SUS304 1種 000-805-494	4
+ナベ・セムソネジ B WASHER HEAD SCREW		M4X20 SUS304 000-804-742	6
付属品 ACCESSORIES		FP14-02301	
ハードカバー組品 HARD COVER ASSY.		FP14-02301 004-375-830	1
その他工材 OTHER INSTALLATION MATERIALS			
ケーブル組品MJ POWER CABLE		MJ-A3SPF0013-035 000-135-397	1
ケーブル組品MJ CABLE ASSY.		MJ-A6SPF0003-050 000-117-603	1

注記) コード末尾に[**]の付いたユニットは代表の型式/コードを表示しています。

DOUBLE ASTERISK DENOTES COMMONLY USED EQUIPMENT.

2.送受波器他オプション等は別梱包になります。

OPTIONS, FOR EXAMPLE TRANSDUCER ARE SUPPLIED IN OTHER BOX.

(略図の寸法は、参考値です。 DIMENSIONS IN DRAWING FOR REFERENCE ONLY.)

DWG NO.

C4394-207-B

2 234±0.5
3 4-φ6 取付穴
FIXING HOLES

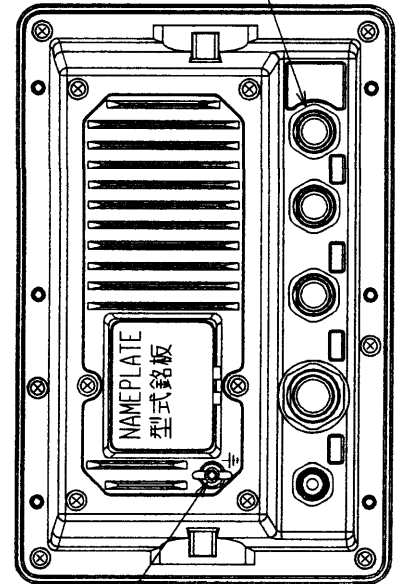

矢視 A
VIEW A



表 1 TABLE 1

寸法区分 (mm) DIMENSION	公差 (mm) TOLERANCE
L ≤ 50	±1.5
50 < L ≤ 100	±2.5
100 < L ≤ 500	±3

表 2 TABLE 2

機種名 TYPE	質量 (kg) MASS
GP-1650F	2.2
GP-1650DF	2.3

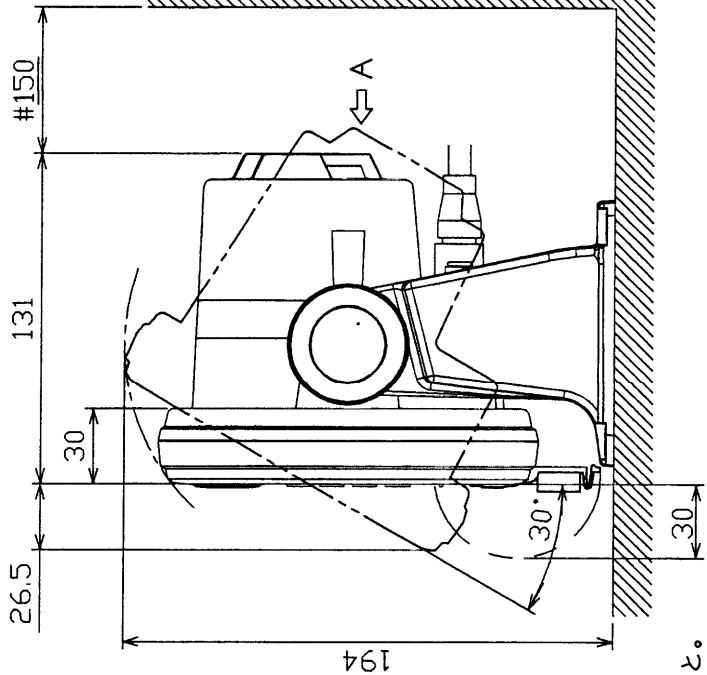
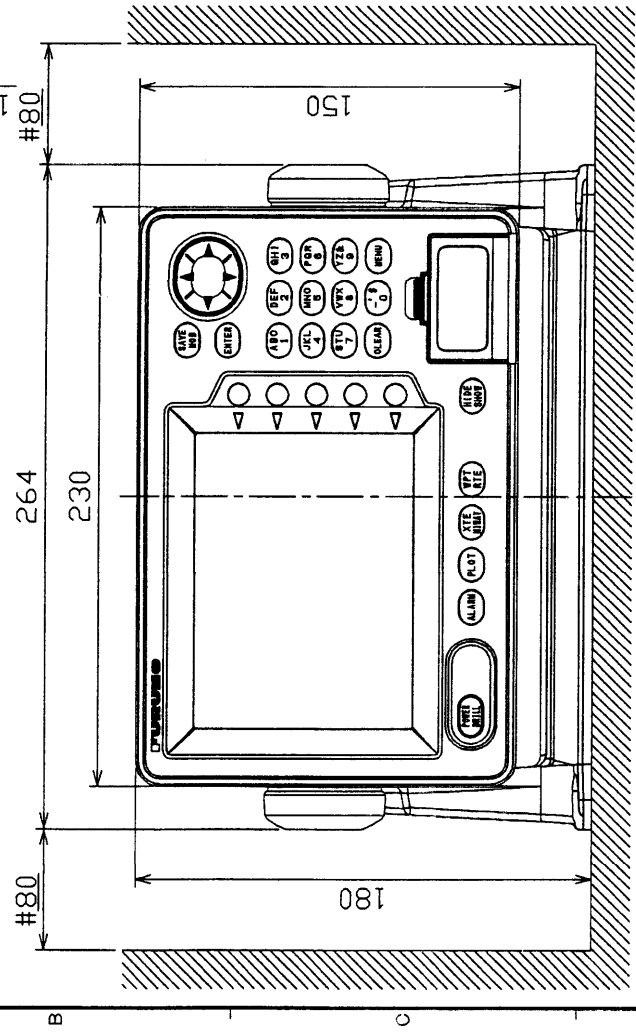
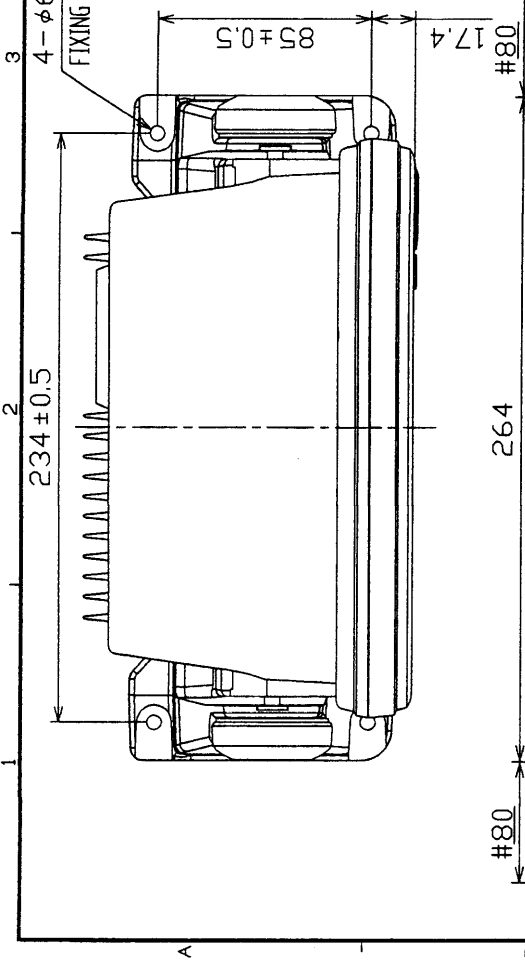

注 記 1) 装備ケーブルはサービス時、本体を前方に十分引き出せるよう余裕を持たせること。
2) 取付用ネジはトラスチックネジ呼び径5×20を使用のこと。
3) 指定外寸法公差は、表1による。
4) #印寸法は最小サービス空間とする。

NOTE 1. KEEP SUFFICIENT CABLE LENGTH BEHIND UNIT.
2. USE TAPPING SCREWS 5x16 FOR FIXING THE UNIT.
3. TABLE 1 INDICATES TOLERANCE OF DIMENSIONS.
4. # RECOMMENDED SERVICE CLEARANCE.

DRAWN Feb. 5 '02 T. YAMASAKI	TITLE GP-1650F/1650DF
CHECKED Feb. 5 '02 Y. UENO	名称 指示部 (卓上装備)
APPROVED Feb. 12 '02 Y. ABE	外寸図
SCALE 1/3	NAME DISPLAY UNIT (DESKTOP MOUNT)
DWG. No. C4394-G03-D	OUTLINE DRAWING 14-062-100G-1

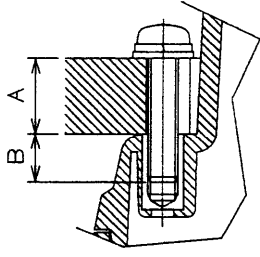
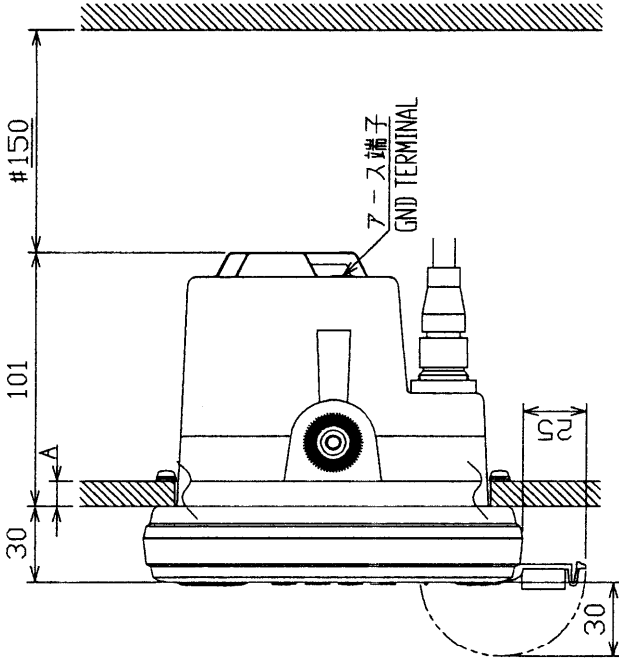
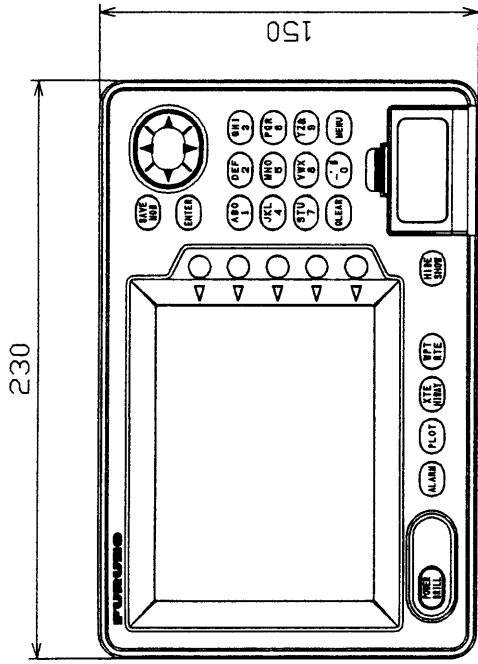

取付ネジ部断面
(尺度 1/1)
DETAIL FOR FASTENING
(SCALE 1/1)

- 注記 1) 装備ケーブルはサービス時、本体を前方に十分引き出せるよう余裕を持たせること。
 2) 指定外寸法公差は表 1 による。
 3) #印寸法は最小サービス空間とする。
 4) 取付にはセムスネジ B M4×2.0 を使用のこと。
 壁の厚さ(A)は $11 \leq A \leq 14$ とする。それ以外の壁に装備する場合、使用するネジ長さは $(A+7.8) \pm 1.5$ とする。筐体にはネジ部(B)を 8 mm 以上いれないこと。

NOTE

- KEEP SUFFICIENT CABLE LENGTH BEHIND UNIT.
- TABLE 1 INDICATES TOLERANCE OF DIMENSIONS.
- # RECOMMENDED SERVICE CLEARANCE.
- USE M4×2.0 SEMS SCREWS FOR FIXING THE UNIT.
THICKNESS (A); $11 \leq A \leq 14$, OTHERWISE SCREW LENGTH; $(A+7.8) \pm 1.5$
DO NOT FASTEN SCREWS INTO UNIT MORE THAN 8 mm. (B \leq 8)

機種名 TYPE	質量 (kg) MASS
GP-1650F	1.9
GP-1650DF	2.0

表 2 TABLE 2

寸法区分 (mm) DIMENSION	公差 (mm) TOLERANCE
$L \leq 50$	± 1.5
$50 < L \leq 100$	± 2.5
$100 < L \leq 500$	± 3

表 1 TABLE 1

DRAWN Feb. 5 '92 T. YAMASAKI	TITLE GP-1650F/1650DF
CHECKED Feb. 5 '92 Y. K.	名称 指示部 (埋込装備)
APPROVED Feb. 5 '92 Y. K.	外寸図
SCALE 1/3 MASS #2 (TABLE 2)	WWE DISPLAY UNIT (FLASH MOUNT)
DWG No. C4394-G04-D	OUTLINE DRAWING 14-062-110G-1

取付穴寸法図
CUTOUT DIMENSIONS

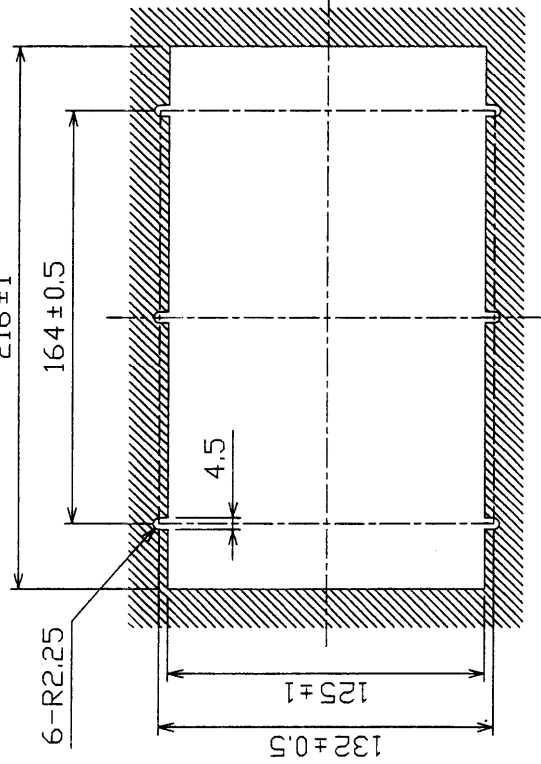

A) MAST MOUNTING

a) USE MAST MOUNTING KIT GP20-01111.

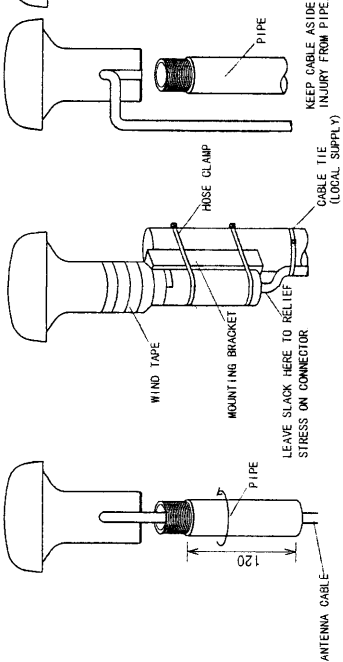

b) USE A PIPE ONLY.

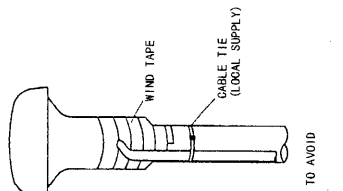

B) HANDRAIL MOUNTING

USE HANDRAIL MOUNTING BASE No. 13-RC5160 (CODE No. 000-806-114, OPTION). THE DIAMETER OF THE HANDRAIL MAY BE FROM $\phi 19\text{mm}$ TO $\phi 32\text{mm}$.

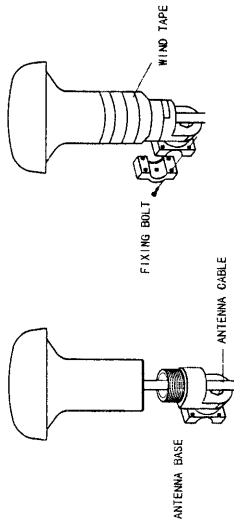

NOTE 1: FASTEN PIPE (ANTENNA BASE) TO ANTENNA UNIT FIRST THEN FIX THEM TO MAST OR HANDRAIL.
2: WHEN FIXING ANTENNA, TURN PIPE OR ANTENNA BASE; NOT THE ANTENNA. TURNING THE ANTENNA MAY TWIST THE CABLE AND PLACE STRESS ON CONNECTOR.

C) ANTENNA BASE MOUNTING

USE OPTIONAL ANTENNA BASE No. 13-0A330/0A310.

INCLINATION	RIGHT ANGLE ANTENNA BASE No. 13-0A330	L-TYPE ANTENNA BASE No. 13-0A310	CODE No.
-5° - 33°			000-803-239
32° - 65°			000-803-240
65° - 98°			

D) MOUNTING DIMENSIONS OF ANTENNA BASE

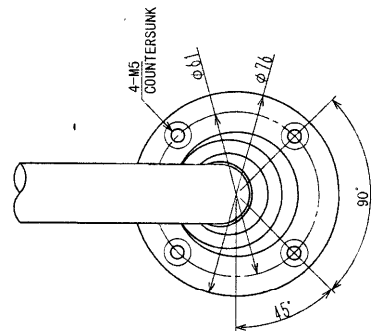

MOUNTING LOCATION

THE FIGURE BELOW SHOWS THE RECOMMENDED SEPARATION DISTANCES FROM OTHER ANTENNAS TO AVOID MUTUAL INTERFERENCE.

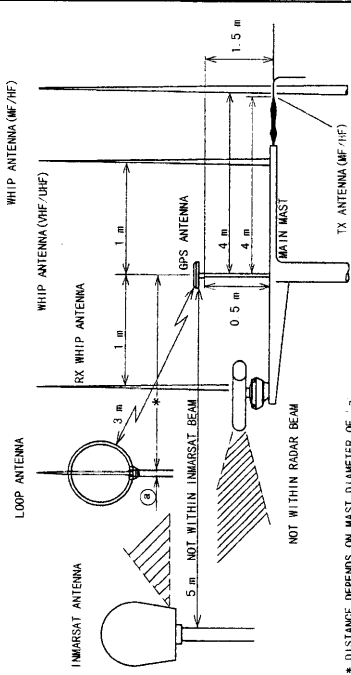

DIA. OF 'a' DISTANCE (MIN.)	a
10 cm	1.5 m
30 cm	3 m

DIMENSION (mm)	TOL. (mm)
$L \leq 50$	± 1.5
$50 < L \leq 100$	± 2.5
$100 < L \leq 500$	± 3

TABLE 1

THREAD DIMENSION (FOR PIPE)
THREAD TYPE: 1x14UNS1B
THREADS PER INCH (25.4mm): 14
PITCH: 1.8143 mm
THREAD LENGTH: 19 mm OR MORE
PITCH DIAMETER: 24.17 mm

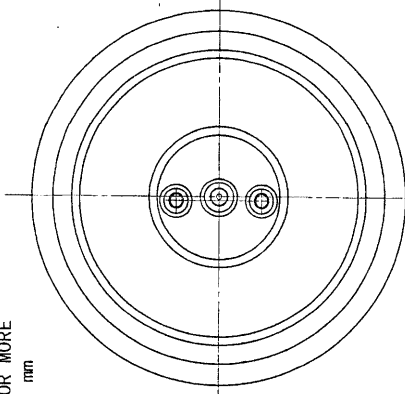

DRAWN	17.99 T. YAMASAKI	TITLE	GPA-017
CHECKED	17.99 K. KAWASAKI	名称	空中線部
APPROVED	17.99 K. KAWASAKI	外寸図	
SCALE	1/1	NAME	ANTENNA UNIT
DWG. No.	E4384-G04-F		OUTLINE DRAWING

NOTE
1. TABLE 1 INDICATES TOLERANCE OF DIMENSIONS.

A) MAST MOUNTING

a) USE MAST MOUNTING KIT GP20-01111.

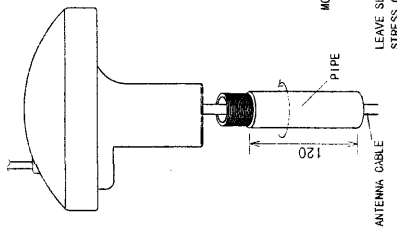

b) USE A PIPE ONLY.

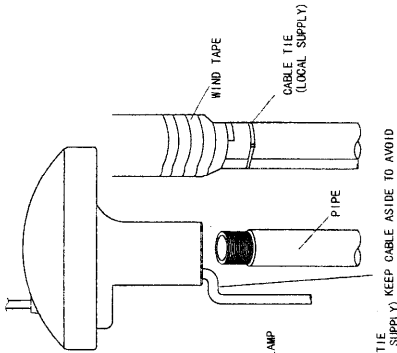

B) HANDRAIL MOUNTING

USE HANDRAIL MOUNTING BASE No. 13-RC5160 (CODE No. 000-806-114, OPTION). THE DIAMETER OF THE HANDRAIL MAY BE FROM $\phi 19\text{mm}$ TO $\phi 32\text{mm}$.

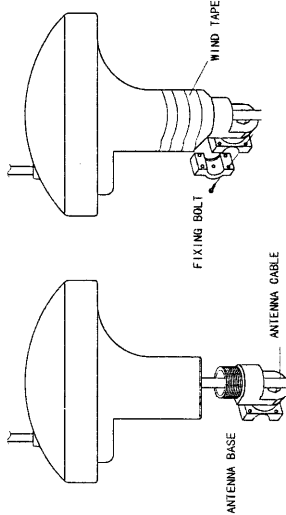

NOTE 1. FASTEN PIPE (ANTENNA BASE) TO ANTENNA UNIT FIRST THEN FIX THEM TO MAST OR HANDRAIL.
2. WHEN FIXING ANTENNA, TURN PIPE OR ANTENNA BASE, NOT THE ANTENNA. TURNING THE ANTENNA MAY TWIST THE CABLE AND PLACE STRESS ON CONNECTOR.

C) ANTENNA BASE MOUNTING

USE OPTIONAL ANTENNA BASE No. 13-0A330/0A310.

INCLINATION	-5° - 33°	32° - 65°	65° - 98°
MOUNTING METHOD			
ANTENNA BASE TYPE	RIGHT ANGLE ANTENNA BASE No. 13-0A330	L-TYPE ANTENNA BASE No. 13-0A310	L-TYPE ANTENNA BASE No. 13-0A310
CODE No.	000-803-239	000-803-240	000-803-240

MOUNTING DIMENSIONS OF ANTENNA BASE

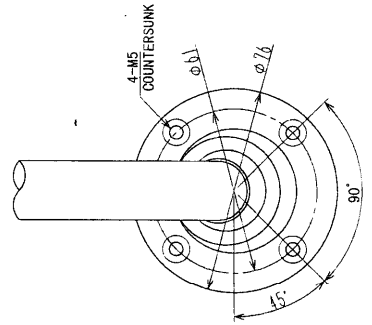

MOUNTING LOCATION THE FIGURE BELOW SHOWS THE RECOMMENDED SEPARATION DISTANCES FROM OTHER ANTENNAS TO AVOID MUTUAL INTERFERENCE.

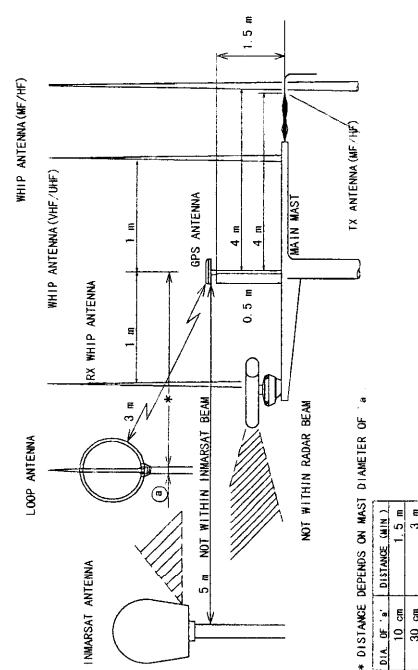

* DISTANCE DEPENDS ON MAST DIAMETER OF

DIAM. OF "A" DISTANCE (MIN.)	1.5 m	3 m
10 cm		
30 cm		

DIMENSION (mm)	TOL. (mm)
$L \leq 50$	± 1.5
$50 < L \leq 100$	± 2.5
$100 < L \leq 500$	± 3

TABLE 1

THREAD DIMENSION (FOR PIPE)
 THREAD TYPE: 1x14UN31B
 THREADS PER INCH (25.4mm): 14
 PITCH: 1.8143 mm
 THREAD LENGTH: 19 mm OR MORE
 PITCH DIAMETER: 24.17 mm

NOTE

1. TABLE 1 INDICATES TOLERANCE OF DIMENSIONS

TABLE 2

TYPE	CABLE LENGTH (m)	PLUG	MASS (kg)
GPA-018	10	TNC-P-3	0.79
GPA-018S	0.2	TNC-J-3	0.35

TITLE GPA-018/018S

名称 空中線部

外寸図

NAME ANTENNA UNIT

OUTLINE DRAWING

DRAWN 12.99 TAKASAKI

CHECKED 12.99 KAWASAKI

APPROVED 12.99 KAWASAKI

SCALE 1/2 MASS TABLE 2

DRG No. E4385-G01-G

A) Mast mounting

Use mast mounting kit CP20-01111.

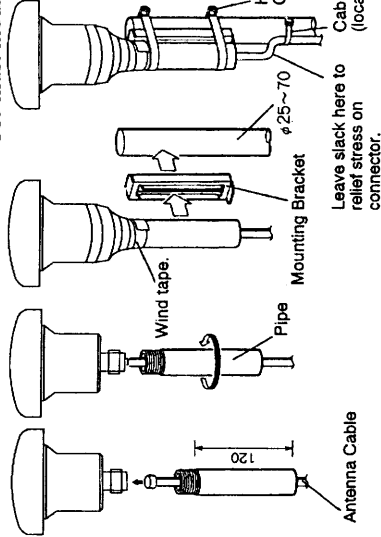

NOTES

- 1) Fasten pipe to antenna first then fix them to mast.
- 2) When fixing antenna to pipe, turn pipe; not the antenna. Turning the antenna may twist the cable and place stress on connector.

Leave slack here to relief stress on connector.

B) Antenna base mounting

Use optional antenna base No.13-QA300 or No.13-QA310.

Inclination	-5° to 33°	32° to 65°	65° to 98°
Right angle antenna base No.13-QA330 (code No. 000-803-239)			
L-type antenna base No.13-QA310 (code No. 000-803-240)			

C) Handrail mounting

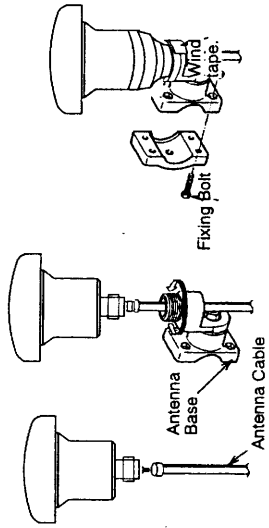

Use handrail mounting base No.13-RCS160 (Code No. 000-861-114, option). The diameter of the handrail may be from $\phi 19\text{mm}$ to $\phi 32\text{mm}$.

NOTES

- 1) Fasten antenna base to antenna first then fix them to handrail.
- 2) When fixing antenna to antenna base, turn antenna base; not the antenna. Turning the antenna may twist the cable and place stress on connector.

Mounting location

The figure below shows the recommended separation distances from other antennas to avoid mutual interference.

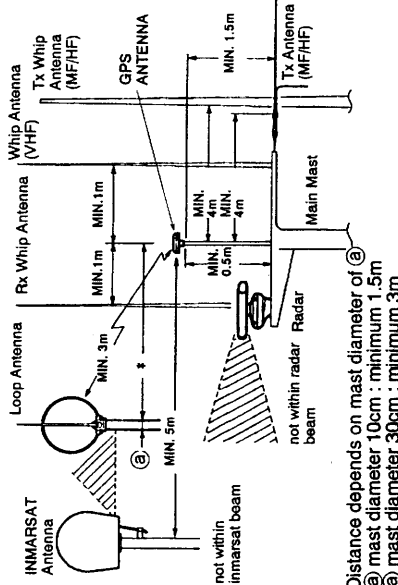

* Distance depends on mast diameter of ϕ
 ① mast diameter 10cm : minimum 1.5m
 ② mast diameter 30cm : minimum 3m

Mounting dimensions of antenna base (option)

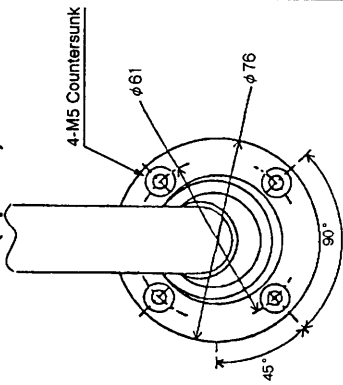

Thread Type	Threads per 25.4 mm (1 Inch)	Pitch	Thread Length	Pitch Diameter
1 X 14UNSB1B	14	1.8143 mm	15.17 mm	24.17 mm

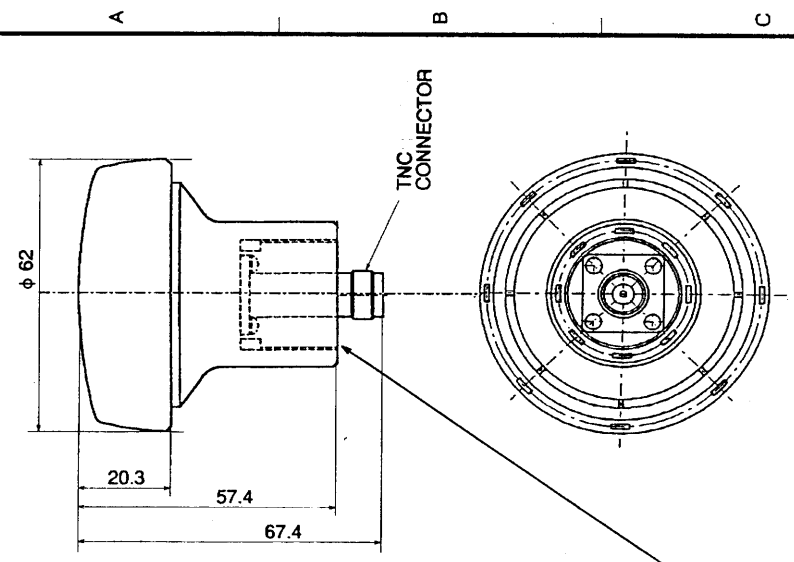

DRAWN	Checked	APPROVED	SCALE	DATE	TYPE	NAME	BLOCK NO.	APPLICABLE TO:	MODEL
M. S. YAMAMOTO	A. YAMAMOTO	M. S. YAMAMOTO	0:1 kg		GP-50MK3 PS-8000M2 GP-1600/F GP-8000M2 GP-3100M2 GP-80	GPA-016 空中線部 外寸図 ANTENNA UNIT			ANTENNA UNIT
DWG. NO. E4374-G04-F									
OUTLINE DRAWING									

A) マストへの取付け MAST MOUNTING
 a) マスト取付套(020-0111)(工事材料)でマストに固定する。
 USE MAST MOUNTING KIT (020-0111).
 b) パイプのみを使うとき
 USE A PIPE ONLY.

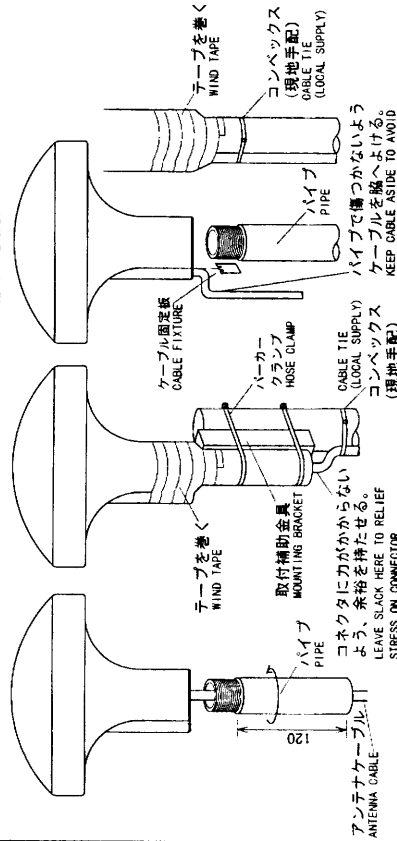

B) スタンションやバルビットにつけるととき HANDRAIL MOUNTING
 レール用アンテナベース No. 13-RC5160 (取付可能レール直径: φ19~φ32)
 (コード番号: 000-800-1114)

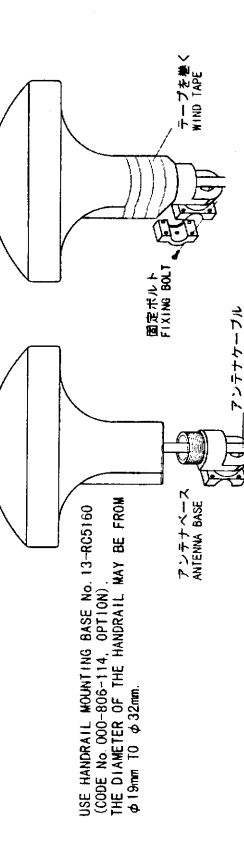

注記 1) パイプ(アンテナベース)はアンテナユニットにねじ込んで固定する。
 2) アンテナを固定するときはパイプ(アンテナベース)をアンテナにねじ込むこと。
 アンテナ側をねじるとコネクタ部やケーブルに無理がかかり、故障の原因となる。
 NOTE 1. FASTEN PIPE (ANTENNA BASE) TO ANTENNA UNIT FIRST THEN FIX THEM TO MAST OR HANDRAIL.
 2. WHEN FIXING ANTENNA, TURN PIPE OR ANTENNA BASE; NOT THE ANTENNA.
 TURNING THE ANTENNA MAY TWIST THE CABLE AND PLACE STRESS ON CONNECTOR.

C) 取付ける場所が傾斜しているとき ANTENNA BASE MOUNTING
 オプションのアンテナベースを使う。
 USE OPTIONAL ANTENNA BASE No. 13-0A330/0A310.

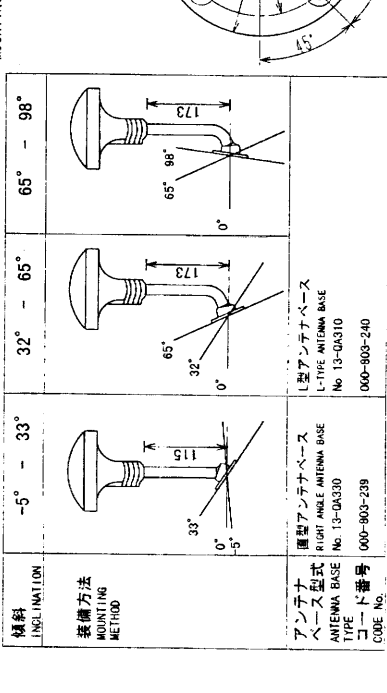

取付場所 MOUNTING LOCATION
 THE FIGURE BELOW SHOWS THE RECOMMENDED SEPARATION DISTANCES FROM OTHER ANTENNAS TO AVOID MUTUAL INTERFERENCE.
 他の機種のアンテナから下の回りの距離以上離す。

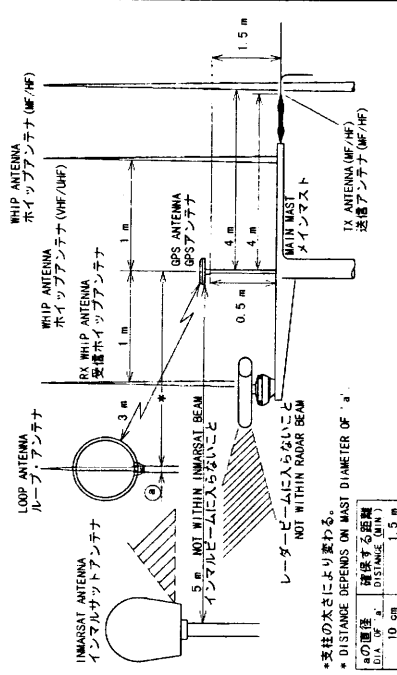

1-14JMS1B
 ねじ山径(25.4mmにつき): 14
 ピッチ: 1.8143 mm
 オネジ有効長さ: 15.17 mm
 オネジ有効径: 24.17 mm
 PITCH: 0.0725 inch (1 INCH): 14
 THREAD LENGTH: 15.17 mm
 PITCH DIAMETER: 24.17 mm

寸法区分 (mm)	DIMENSION	公差 (mm)	TOL.
L ≤ 50		± 1.5	
50 < L ≤ 100		± 2.5	
100 < L ≤ 500		± 3	

表 1 TABLE 1

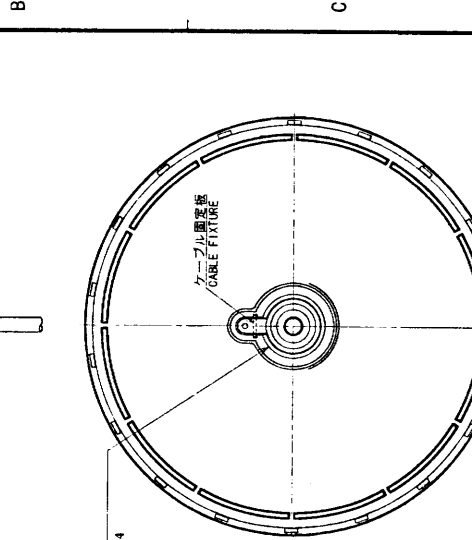
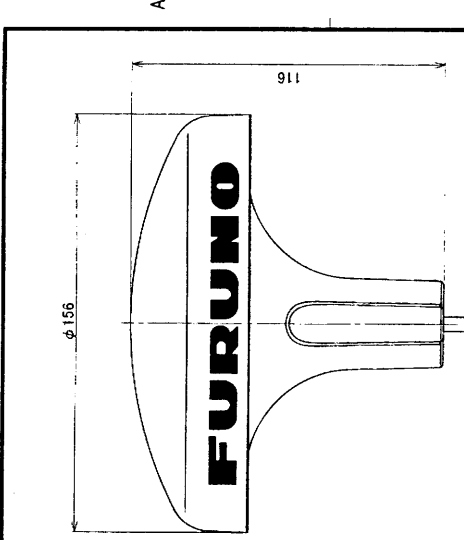

型式 TYPE	ケーブル長さ(m) CABLE LENGTH	プラグ PLUG	質量(kg) MASS
GPA-019	10	TNC-P-3	1.0
GPA-019S	0.2	TNC-J-3	0.54

表 2 TABLE 2

注記: 指定外の寸法公差は表 1 による
 NOTE: TABLE 1 INDICATES TOLERANCE OF DIMENSIONS.

DRAWN	CHECKED	APPROVED	SCALE	DATE	FIG. No.
1998.12.17	1998.12.17	1998.12.17	1/2	表 2 参照	C4400-601-D



表1 TABLE 1

寸法区分(mm) DIMENSION	公差(mm) TOLERANCE
0 < L ≤ 50	±1.5
50 < L ≤ 100	±2.5
100 < L ≤ 500	±3

ケーブル導入口
CABLE ENTRY

24VDC
OUTPUT
(2.5A max)

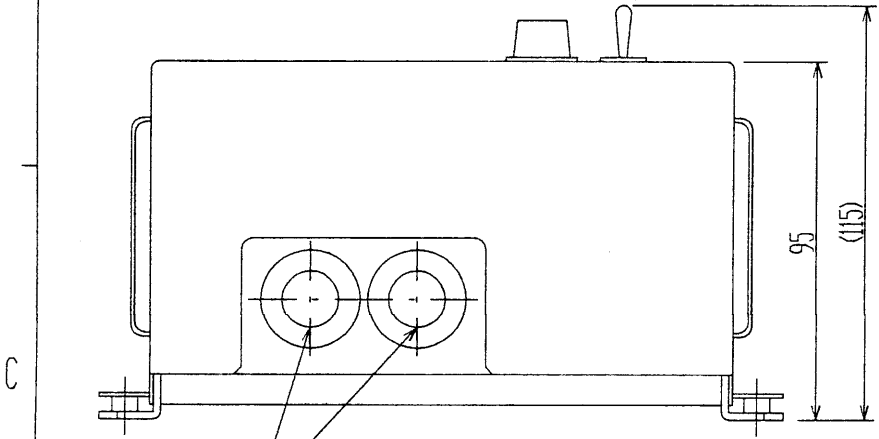
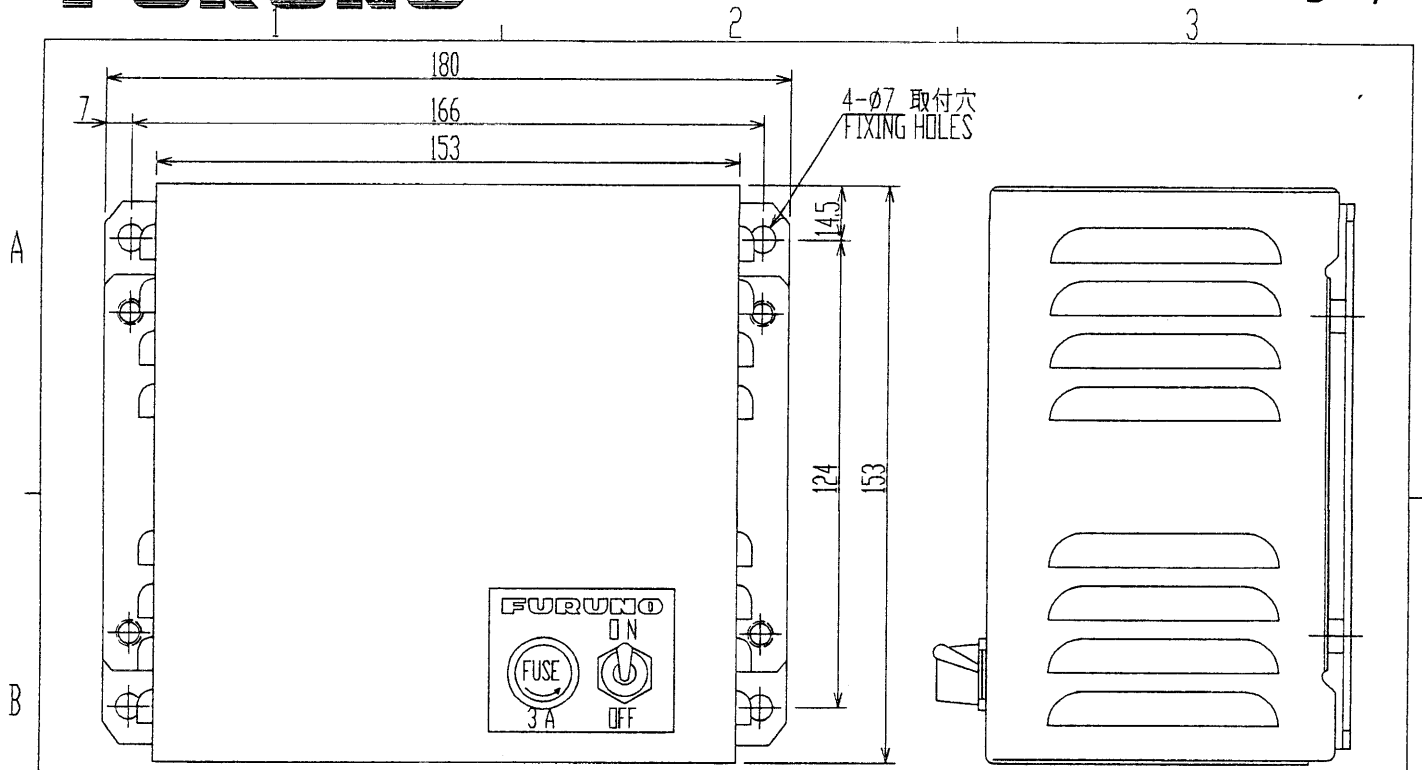
AC INPUT

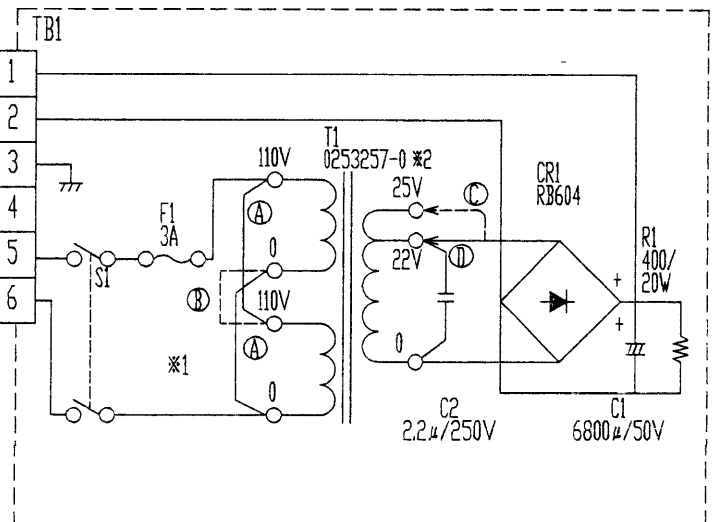

入力電圧に応じて接続を変更して下さい。
CHANGE TAP CONNECTIONS DEPENDING ON SUPPLY VOLTAGE.

	AC100V	AC110/ 115V	AC220V	AC230V
※1	(A)	(A)	(B)	(B)
※2	(C)	(D)	(D)	(D)

DRAWN Sep. 14 '01 CHECKED APPROVED SCALE 1/2 DWG.No. C5003-034-E	T.YAMASAKI Y.KI Y.KI MASS 3 ±10% kg	TITLE PR-62 名称 整流器 外寸図 NAME RECTIFIER OUTLINE DRAWING
---	---	--

1 2 3 4

ホイップアンテナ
1.2m WHIP ANTENNA
(OPTION FOR EXPORT)
FAW-1.2

空中線部
ANTENNA UNIT

いずれかを選択
SELECT ONE TYPE

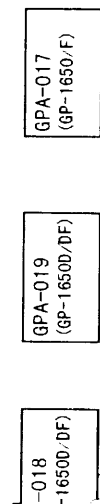

GP-1650/D/F/DF
DISPLAY UNIT
指示器

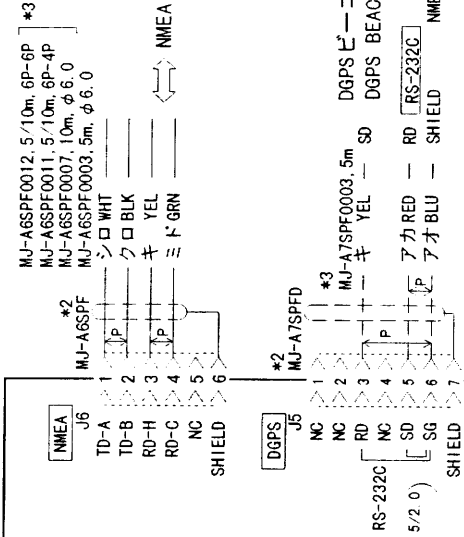

DGPS ビーコン受信機
DGPS BEACON RECEIVER

RS-232C
NMEA0183 in RS232C LEVEL *5

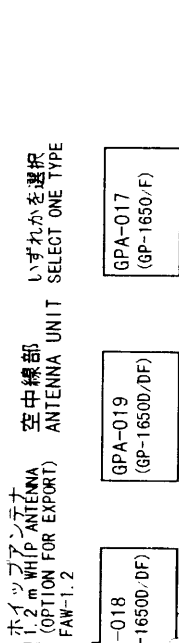

船内電源
SH1P'S MAINS 02S4094, 3.5m, φ8.0
12-24 VDC
100/110/220V/DPYC-1.25 *1
230VAC, 50/60Hz, 1φ

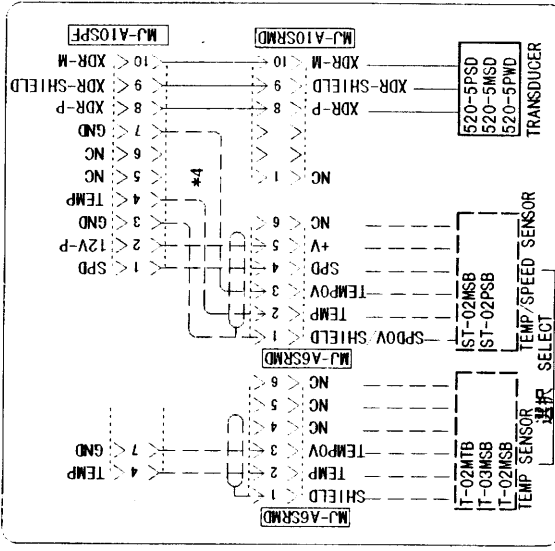
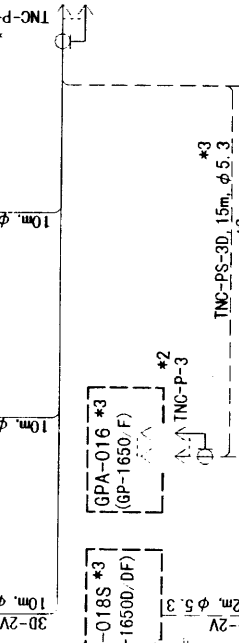

水温・船速センサー付
送受波器
TRANS-DUCER W/
TEMP./SPEED SENSOR

520ST-PWD
524ST-MSD

送受波器
TRANS-DUCER
OPTION FOR EXPORT

520-5PSD
520-5PWD
520-5MSD

注記

- * 1) 現地手配
- * 2) コネクタは工場にて取付済み
- * 3) オプション
- * 4) 変換ケーブル組品 (オプション) が必要。
- * 5) オプションのレベル変換器にはオプションのケーブルが必要。

NOTE

- * 1. LOCAL SUPPLY.
- * 2. FITTED AT FACTORY.
- * 3. OPTION
- * 4. THREE-WAY CONVERSION CABLE NEEDED (OPTION).
- * 5. OPTIONAL LEVEL CONVERTER REQUIRED FOR CURRENT LOOP OR RS422 OUTPUT.

DRAWN <i>May 17 1997 T. Yamazaki</i>	TITLE GP-1650/D/F/DF
CHECKED <i>May 17 1997 K. Kawada</i>	名称 カラーGPSプロッタ
APPROVED <i>May 17 1997 K. Kusuriki</i>	相互結線図
SCALE 1/1000	NAME COLOR GPS PLOTTER
DWG. No. C4394-C01-F	INTERCONNECTION DIAGRAM

